



*Screen Creator 5 User's Manual*  
*Vol. 3*



**Screen Creator 5**  
**Connection with PLC**  
**and**  
**External Equipment**



**KOMATSU**

Electronic System & Component Dept.

---

Electronics Div.

# Notes on Use of This Manual

This manual explains how to communicate with a PLC and a host computer, as well as how to connect peripheral devices to this system. Please read this manual thoroughly to understand the functions and performance of this system and assure correct and safety operations.

This manual configuration is as shown below:

CHAPTER I	GENERAL DESCRIPTION	This section explains communication parameters, interface specifications, and other necessary items common to each communication type.
CHAPTER II	CONNECTION TO A PLC	This section explains PLC types connectable to this system and how to connect each maker's PLC to this system.
CHAPTER III	COMMUNICATION WITH A HOST COMPUTER (Command Communication)	This section explains how to communicate with a host computer using the command communication method.
CHAPTER IV	COMMUNICATION WITH A HOST COMPUTER (Non Procedure Communication)	This section explains how to communicate with a host computer using the no-protocol communication method.
CHAPTER V	COMMUNICATION WITH A HOST COMPUTER (Memory Link Communication)	This section explains how to communicate with a host computer using the memory link communication method.
CHAPTER VI	PERIPHERAL UNIT CONNECTION	This section explains how to connect this system to peripheral devices including a printer, a bar-code reader, etc., as well as peripheral device types connectable to this system.

It is also recommended to refer to the following manuals together with this one.

Vol.1	Screen Creator 5 Operation Manual (Introduction)	This manual explains the basic operation methods of Screen Creator 5.
Vol.2	Screen Creator 5 Operation Manual (Details)	This manual explains individual operations of Screen Creator 5 in detail.
Vol.3	Screen Creator Operation Manual: Connection with PLC and External Equipment	This manual explains how to communicate with the PLC and host computer and connect with external equipment.
Vol.4	Standard Parts Catalog	This catalog explains the functions of the standard parts our company provides.
Vol.5	Screen Creator Operation Manual: Control Reference	This reference manual explains the controls used to create parts.
Vol.6	Screen Creator 5 Operation Manual (K-Basic Program Description)	This manual explains how to describe programs to draw screens, and the commands of Screen Creator 5.
Vol.7	List of Error Codes	This manual describes the restrictions for creating screens using Screen Creator 5, as well as how to process errors, and error codes to appear when those errors occur.

# Safety Precautions

Be sure to follow the safety precautions listed below in order to use this system safely. Koyo cannot be held liable for any damages incurred if these safety precautions are not followed.



- Design your system so that there are sufficient countermeasures for personnel accidents and major equipment accidents. The system should have an external protection and safety circuit, so that even if the OIP should malfunction or even if there is a defect in the program the safety of the system is assured.
- Do not use the touch panel of the OIP to make switches that are related to safety or people or major damages (emergency safety switches, etc.). Be sure the system is designed so that it can cope with any errors or malfunctions in the touch panel.
- Be sure that class 3 grounding is used for the protective grounding terminal. There is a possibility of electrical shock if the unit is not grounded.
- If the OIP should malfunction, immediately turn off the power and leave it alone.
- If there is direct output to external output devices such as PLCs, direct output will be driven regardless of the ladder circuit interlock. Output may be used to drive motors and the like, so avoid using direct output because it is dangerous.

## CAUTION

- Use and store the OIP in the environment described in the specifications (regarding vibrations, shock, temperature, humidity, etc.).
- Do not use the OIP where it is subjected to inflammable or explosive gases, or steam.
- Before turning on the power, be sure that the power voltage rating of the OIP and the voltage rating of power supply match. Using a mistaken power supply can damage the unit.
- Do not disassemble or modify the OIP. Doing so can cause malfunctions and lead to other problems.
- The OIP touch panel is made of glass. Striking it with hard objects or pressing hard on it may break the glass.
- Do not push down on the OIP touch panel with mechanical pencils, screwdrivers or other sharp objects. Doing so can damage the touch panel or cause malfunctions.

# Notation

This user's manual uses the following symbol marks to assure safety operations of this system.



Describes a peril that may cause operator's death or serious injury when in neglecting the WARNING item(s).



Describes a peril that may cause bodily injury or serious device damage when in neglecting the CAUTION item(s).



This mark indicates a caution on general operations.

**Note:** Explanations and supplemental items.

This manual also uses the following terms.

OIP	OIP stands for Advanced Intelligent Panel.
PLC	A PLC indicates a programable controller. It is also referred to as a sequence controller.
Link unit	"Link Unit" is a generic name for communication units used to connect this OIP to a PLC. Since the name of this unit differs among makers, we call it that way generally.
Device	"Device" is a generic name for I/O relays, internal relays, timers, counters, registers, etc. used for PLC.

# Notice

**This manual has been carefully prepared and reviewed for completeness and correction. However, we assume no responsibility for any consequences including indirect losses which may arise from the use of this manual or for any errors which it may contain including technical, proofreading, and omission errors.**

1. No parts of this document may be reproduced or copied in any form without the prior written permission.
2. The contents of this manual are subject to change without prior notice.
3. This document has been carefully prepared and reviewed for completeness and correctness. However, contact the Sales Dept. of Koyo concerning any errors which may notice or on any points on which you are in doubt.
4. Koyo shall not be liable for incidental or consequential damages in connection with the use of this document regardless of the result of the said item 3.
5. Koyo makes no warranties of any industrial and other properties with regard to this document. Koyo also assumes no responsibility for any issues of industrial properties and other proprietary rights including such patent issues as information, circuits, equipment or software described in this document, which may arise from the use of this document.
6. Contact us at the following places concerning other unclear points in this document.

**Customer Support Group  
Sales Dept.  
Electronics Division  
Komatsu Ltd.**

**Address: 4-20-1, Kamata, Ota-ku, Tokyo 144-0052  
Telephone No.: 81-3-5711-1838  
Facsimile No.: 81-3-5711-1840  
E-MAIL: panel.el.@komatsu.co.jp**

# Version Up

Koyo Ltd. has upgraded Screen Creator 5 for adding new functions, operationability and so forth. Below will be introduced the updated functions.

## 1. Version 2.10

- Supporting middle size systems (GC53) of GC5x Series
- Adding the uploading editing function  
To make this function effective, attach all screen data and K-Basic programs used in the project and download them to the panel. Then download the uploaded entities from the panel and restore them. Then you can edit the data and programs. Note that the data with the project attached increase their size.
- The following PLCs have been added.

Omron	SYSMAC a
Fuji Denki	FLEX-PC NJ-T/NS-T
Fuji Denki	Computer-link protocol
Fuji Denki	Loader command protocol
Toyota Koki	PC1
Toyota Koki	PC3
Matsushita Electric Industry	Panadac 7000
- Standard components, centered on the parts used for middle size systems (GC53) in the GC5x Series have drastically been added.

# CONTENTS

## CHAPTER I GENERAL DESCRIPTION

1. FEATURES.....	I-2
2. COMMUNICATION INTERFACE SPECIFICATIONS.....	I-3
2.1 RS-232C.....	I-3
2.2 RS-442/485 (CH3).....	I-5
3. BEFORE TRIAL OPERATION .....	I-7
3.1 Setting Communication Type .....	I-7
3.2 Setting Communication Parameters .....	I-8
4. TROUBLESHOOTING .....	I-10
4.1 Errors and Error Processings.....	I-10
4.2 Communication Error Codes.....	I-11

## CHAPTER II CONNECTION TO A PLC

1. OUTLINE .....	II-2
2. NOTES FOR USE .....	II-3
3. SETTING PLC MANUFACTURER NAME AND MODEL NUMBERS .....	II-5
4. SETTING DEVICE NAMES.....	II-7
5. SETTING COMMUNICATION PARAMETERS.....	II-9
6. CONNECTION OF SEVERAL OIP UNITS (M:N COMMUNICATION) .....	II-10
7. LIST OF CONNECTABLE PLC TYPES .....	II-12
<b>1. PLC Supplied by Mitsubishi</b>	
1.1 AnN, AnS (for link unit).....	II 1-1
1.2 AnA, AnU, AnUS (for link unit) .....	II 1-4
1.3 QnA .....	II 1-6
1.4 A Series (Direct Connection to CPU).....	II 1-8
1.5 FX Series.....	II 1-11
<b>2. PLC Supplied by OMRON</b>	
2.1 SYSMAC C, CQM1, CPM1 .....	II 2-1
2.2 SYSMAC ( Series).....	II 2-4
2.3 SYSMAC (CV Series).....	II 2-6
<b>3. PLC Supplied by Fuji</b>	
3.1 FLEX-PC (NJ, NS or NB Series).....	II 3-1
3.2 FLEX-PC (NJ-T, NS-T Series) .....	II 3-4
3.3 FLEX-PC (Computer link).....	II 3-7
3.4 FLEX-PC (Loader command).....	II 3-10
3.5 MICREX-F Series.....	II 3-12
<b>4. PLC Supplied by Hitachi</b>	
4.1 H-Series (with station number assignment) .....	II 4-1
4.2 H-Series (without station number assignment) .....	II 4-4



<b>5. PLC Supplied by Sharp</b>	
5.1 New Satellite JW Series (for link unit) .....	II 5-1
5.2 JW (for communication port) .....	II 5-4
<b>6. PLC Supplied by Toyota Koki</b>	
6.1 TOYOPUC PC1 Series .....	II 6-1
6.2 TOYOPUC PC2 Series .....	II 6-3
6.3 TOYOPUC PC3 Series .....	II 6-5
<b>7. PLC Supplied by Yasukawa</b>	
7.1 GL Series, U84, CP-9200.....	II 7-1
7.2 Inverter (VS-616G5).....	II 7-4
<b>8. PLC Supplied by Yokogawa</b>	
8.1 FA500, FA-M3 (CPU No. fixed).....	II 8-1
8.2 FA500, FA-M3, UT2000 (CPU No. variable).....	II 8-5
<b>9. PLC Supplied by Matsushita</b>	
9.1 FP Series.....	II 9-1
<b>10. PLC Supplied by Matsushita</b>	
10.1 Panadac 700 Series .....	II 10-1
<b>11. PLC Supplied by Toshiba</b>	
11.1 EX Series.....	II 11-1
11.2 T Series .....	II 11-3
<b>12. PLC Supplied by Yamatake-Hoenywell</b>	
12.1 MA500 .....	II 12-1
<b>13. PLC Supplied by Keyence</b>	
13.1 KZ300 .....	II 13-1
13.2 KZ-A500 .....	II 13-4
<b>14. PLC Supplied by Toyo</b>	
14.1 $\mu$ -GPCH Series.....	II 14-1
<b>15. PLC Supplied by A-B</b>	
15.1 SLC500.....	II 15-1
<b>16. Multipanel Unit</b>	
16.1 ???.....	II 16-1
<b>APPENDIX LINK UNIT SETTING</b>	
1. Setting the Computer Link Unit (AJ71UC24) of Mitsubishi .....	II A-1
2. Setting the Computer Link Unit (AJ71C24) of Mitsubishi .....	II A-2
3. Setting the C200H-LK101/LK201/LK202 of Omron .....	II A-3
4. Setting C500-LK101/LK201-V1 of Omron .....	II A-4
5. Setting C500-LK203 of Omron .....	II A-5
6. Setting CV500-LK201 of Omron.....	II A-6
7. Setting CQM1-CPU21 of Omron .....	II A-7

8. Setting COMM Module (COMM-H/COMM-2H) of Hitachi .....	II A-8
9. Setting ZW-10CM of Sharp .....	II A-9
10. Setting the Communication Module (IOP, COMM) of Yasukawa.....	II A-10
11. Setting the Personal Computer Link Module (F3LC01-1N) of Yokogawa.....	II A-11
12. Setting the Personal Computer Link Module (LC02-1N) of Yokogawa.....	II A-12
13. Setting the Computer Communication Unit (CCU) of Matsushita .....	II A-13
14. Setting the Link Unit (T Series) of Toshiba.....	II A-14
15. Setting the CPU Unit (EX100) of Toshiba .....	II A-15

### **CHAPTER III COMMUNICATION WITH A HOST COMPUTER (Host Command Communication)**

1. OUTLINE .....	III-2
2. PROTOCOL SPECIFICATIONS .....	III-3
2.1 How to Communicate .....	III-3
2.2 Packet Structures .....	III-3
2.3 Data Structures .....	III-4
3. SETTING THE TYPE OF PROTOCOL .....	III-6
4. SETTING A COMMUNICATION FORMAT .....	III-7
5. SETTING COMMUNICATION PARAMETERS.....	III-8
6. CABLE CONNECTION.....	III-9

### **CHAPTER IV COMMUNICATION WITH A HOST COMPUTER (Non Procedure Communication)**

1. OUTLINE .....	IV-2
2. SYSTEM SETTING .....	IV-2
3. HOW TO DESCRIBE A PROTOCOL WITH K-BASIC .....	IV-3
3.1 Notes on Describing with K-Basic .....	IV-3
3.2 Programing Examples .....	IV-4
4. ERROR PROCESSINGS .....	IV-6

### **CHAPTER V COMMUNICATION WITH A HOST COMPUTER (Memory Link Communication)**

1. OUTLINE .....	V-2
2. MEMORY TABLES.....	V-2
3. DIFFERENCES BETWEEN TYPE I AND TYPE II.....	V-2
4. METHODS OF COMMUNICATION (Issuing commands between the OIP and the host). .....	V-3
4.1 List of Commands .....	V-3
4.2 Memory Table Batch Reading (in word).....	V-4
4.3 Memory Table Batch Writing (in word).....	V-6
4.4 Memory Table Random Reading (in word).....	V-8
4.5 Memory Table Random Writing (in word) .....	V-10
4.6 Memory Table Random Writing (in bit) .....	V-12
4.7 Data Transmission from the OIP to the Host by Switch Entry etc. ....	V-14

5.	ERROR RESPONSE – Only for Type II .....	V-16
5.1	Format of the Error Response .....	V-16
5.2	Error Codes .....	V-16
6.	SCREEN CREATION .....	V-17
7.	RESTRICTIONS .....	V-17
8.	SETTING PROTOCOL TYPE .....	V-18
9.	SETTING COMMUNICATION PARAMETERS .....	V-18
10.	SETTING A STATION NUMBER .....	V-18
11.	CABLE CONNECTION .....	V-19

## CHAPTER VI CONNECTION TO PERIPHERAL UNIT

1.	SETTING A MODEL .....	VI-2
2.	SETTING COMMUNICATION PARAMETERS .....	VI-2
3.	PRINTER .....	VI-3
3.1	Function .....	VI-3
3.2	Connectible Models .....	VI-3
3.3	Printing a Screen .....	VI-4
3.4	Setting Printer Parameters and Notes for Use .....	VI-4
3.5	System Setting .....	VI-5
3.6	Cable Connection .....	VI-6
4.	BAR-CODE READER .....	VI-7
4.1	Function .....	VI-7
4.2	???	VI-7
4.3	Token's TCD8200/TCD8500 .....	VI-8
5.	TEN-KEY BOARD .....	VI-10
5.1	Function .....	VI-10
5.2	Specifications .....	VI-10
5.3	Dimensional Outline Diagrams .....	VI-11



---

# **CHAPTER I**

## **GENERAL DESCRIPTION**

## 1. FEATURES

---

Some of the major features of the Advanced Intelligent Panel (OIP) are listed below.

**RS-232C and RS-422/RS-485 connectors provided as standard**

The OIP has independent RS-232C and RS-422/RS-485 communication interface cable connectors. It can expand another channel of the RS-232C connector as an option. Thus, a host computer, controllers, and peripheral units (such as a printer, a bar-code reader, and a ten-key pad), as well as PLCs, can be connected together to the OIP, and have flexibility to correspond to many different kinds of systems.

**Easy connection to various external units**

The OIP takes a format in which the software of the communication driver for connecting PLCs and other external units is to be downloaded together with screen data. Users, therefore, can readily connect the OIP to various external units, such as PLCs and peripheral units of different manufacturers, without having to modify the hardware of the OIP.

The OIP was also designed with enough flexibility for connection to new PLCs and to optional features.

## 2. COMMUNICATION INTERFACE SPECIFICATIONS

### 2.1 RS-232C

#### 1) Transmission specifications

No.	Item	Description
1	Mode of communication	Full-duplex
2	Method of synchronization	Start-stop
3	Transmission distance	15 m
4	Connection format	1 : 1
5	Transmission rate	1200, 2400, 4800, 9600, 19200 or 38400 bps (to be set using a communication parameter)
6	Data format	Start bits: 1 Stop bits: 1 or 2 Data length: 7 or 8 bits Parity: Even, odd, or none (to be set using a communication parameter)

#### 2) Connector pin numbers and signal names

- CN1 (CH1)

Pin	Pin name	Direction	Description
1	FG		Frame ground
2	SD	Output	Sending data
3	RD	Input	Receiving data
4	RS	Output	Request to send signal
5	CS	Input	Clear to send signal
6	Not used		
7	SG		Signal ground
8	Not used		
9	+5 V		+5 V power (for optional unit)

- CN2 (CH2 is an option only for GC56LC/GC55EM)

Pin	Pin name	Direction	Description
1	FG		Frame ground
2	SD	Output	Sending data
3	RD	Input	Receiving data
4	RS		Request to send signal
5	CS		Clear to send signal
6	Not used		
7	SG		Signal ground
8	Not used		
9	+5 V		+5 V power (for optional unit)

### 3) Connector pin assignment (OIP side)

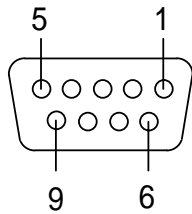

- Usable connectors  
 Plug: HDEB-9P (Hirose Denki) or equivalent  
 Shell: HDE-CTF (Hirose Denki) or equivalent



## 2.2 RS-442/485 (CH3)

### 1) Transmission specifications

No.	Item	Description
1	Mode of communication	Full-duplex, five-wire or half-duplex, three-wire
2	Method of synchronization	Start-stop
3	Transmission distance	500 m
4	Connection format	1 : N (N ≤ 31) M:N (M+N ≤ 32) M:OIP, N:PLC
5	Transmission rate	1200, 2400, 4800, 9600, 19200 or 38400 bps (to be set using a communication parameter)
6	Data format	Start bits: 1 Stop bits: 1 or 2 Data length: 7 or 8 bits Parity: Even, odd, or none (to be set using a communication parameter)

### 2) Connector pin numbers and signal names (in case of 15-pin connector)

Pin	Pin name	Direction	Description
1	RDB	Input	Receiving data (-)
2	(CTS)	Input	Clear to send signal (Note)
3	SG1		Signal ground
4	SDB	Output	Sending data (-)
5	SDB	Output	Sending data (-)
6	SG2		Signal ground
7	(RTS)	Output	Request to send signal (Note)
8	RDB	Input	Receiving data (-)
9	RDA	Input	Receiving data (+)
10	FG1		Frame ground
11	SDA	Output	Sending data (+)
12	(+5V)		5V power supply (for optional devices) (Note)
13	SDA	Output	Sending data (+)
14	FG2		Frame ground
15	RDA	Input	Receiving data (+)

**Note:** CTS and RST signals cannot be used for RS-485 because of extended signals.

### 3) Connector pin assignment (OIP side)

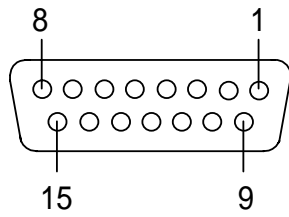

- Usable connectors  
Plug: HDAB-9P (Hirose Denki) or equivalent  
Shell: HDA-CTF (Hirose Denki) or equivalent

### 4) Internal circuits

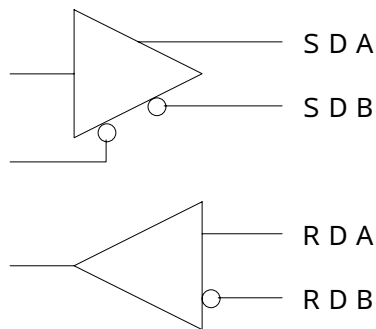

Since no terminator is provided, solder a terminator to a pin of the connector as needed.

## 3. BEFORE TRIAL OPERATION

### 3.1 Setting Communication Type

Set the object devices to the communication port as follows:

Select "System Setup" from the system mode menu.

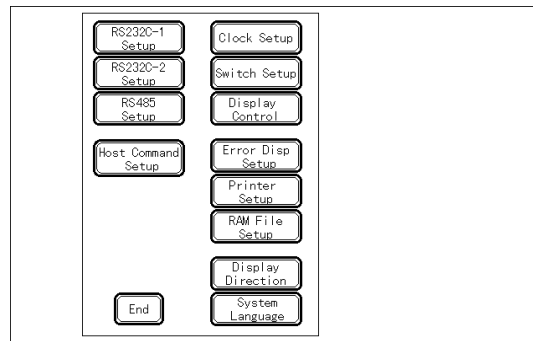

Select the communication port from the system setting menu.

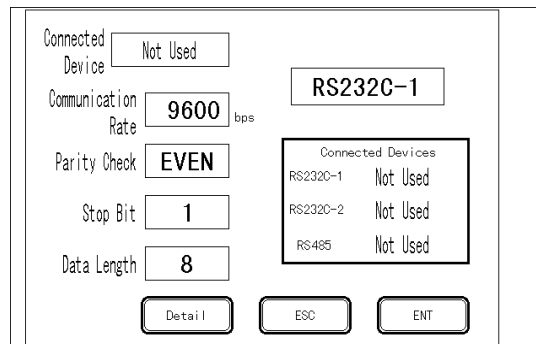

Touch the communication "Connected Device" frame. The device selection menu appears. Then, touch the device to connect. This selection is ignored unless a communication protocol is downloaded together with screen data beforehand.

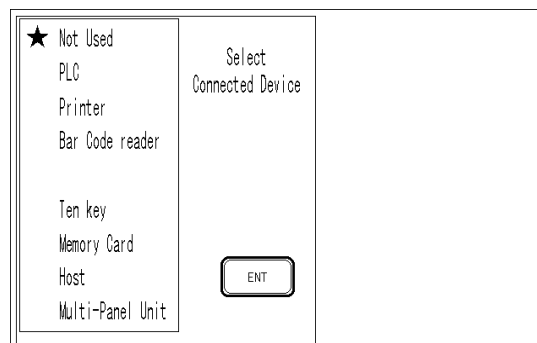

Click [OK] to return to the screen .

If an attempt is made to set another communication port here, it is regarded as an error. In such a case, set "Not Used" for another communication port and retry the setting.

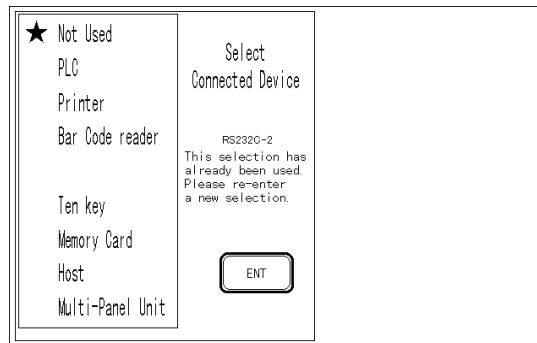

## 3.2 Setting Communication Parameters

### 1) Communication rate

Set the communication speed according to the object remote device. (The default value is 9600 bps.)

Touch the "Communication rate" frame on the screen (3-1- ). Each time you touch the frame, the value will change cyclically as follows:

9600 → 19200 → 38400 → 1200 → 2400 → 4800 → 9600

### 2) Parity check

Set the parity bit length according to the object remote device. (The default value differs among devices to select.)

Touch the "Parity check" frame on the screen (3-1- ). Each time you touch the frame, the value will change cyclically as follows:

EVEN (even number) → NONE (no parity) → ODD (odd number) → EVEN

### 3) Stop bit

Set the stop bit length according to the object remote device. (The default value differs among devices to select.)

Touch the "Stop Bit" frame on the screen (3-1- ). Each time you touch the frame, the value will change cyclically as follows:

1 → 2 → 1

### 4) Data length

Set the data length according to the object remote device. (The default value differs among devices to select.)

Touch the "Data Length" frame on the screen (3-1- ). Each time you touch the frame, the value will change cyclically as follows:

8 → 7 → 8

## 5) Setting details

Select "Setting details" on the screen (3-1- ). The following screen appears.

In case of RS-232C

Retry Count	Time Out	ID Number
1	3.0 sec.	0
X on/off	OFF	ENT

In case of RS-485

Retry Count	Time Out	ID Number	ID Number
1	3.0 sec.	0	0
X on/off	OFF	ENT	

### Retry count

Set the number of times to retry when a communication error occurs. Input range: 0 to 7. The default value differs among devices to select.

### Time out

Set the limit time to generate a time-out error when no response is returned. Input range: 1.0 to 25.5 sec. The default value differs among remote devices.



**If this value is set to 0.0, the Screen Creator waits until a communication response is returned.**

### Machine ID number

Set the OIP ID number used when the command communication method or the memory link communication method (memory-to-memory communication method) is used for communications with a host computer, etc. Input range: 0 to 255. Default value: 0

This parameter is not needed when OIP is connected to a PLC and peripheral devices.

### Next machine ID number (Applicable to RS-485 only.)

The next machine ID number is assigned to the next one of OIPs connected with the PLC using no multi-panel units (M:N communication). The input range is between 0 and 255. The default value is 0. For details, refer Section 6, "Connecting Several OIP Units (M:N Communication)" of Chapter II.

Set this ID number to 0 when M:N connection is not carried out.

### Xon/off

Select whether to control Xon/Xoff.

The default value differs depending on remote devices.

## 4. TROUBLESHOOTING

This section will explain errors to occur while this system is used for communications, as well as how to identify their causes and how to correct them.

### 4.1 Errors and Error Processings

The table below explains how to identify error causes and how to correct those errors according to their symptoms.

Symptom	Cause	Corrective Action
No communication can be made.	The communication cable is not connected.	Connect the cable correctly.
	The power to the remote device is not turned on.	Turn on the power to the remote device.
	An improper communication cable is used.	Replace the cable.
	The devices are not set correctly for "Environmental" of Screen Creator 5.	Set those devices according to the object PLC.
	The link unit is not set correctly. (Communication mode and protocol)	Set the link unit correctly.
	Communication parameters are set differently between this system and remote system. (Communication rate, parity bit, stop bit length, and data length)	Correct the parameters so that they match between both systems.
	The serial port communication type is not set correctly.	Correct the communication type. (Refer to Section 3, "BEFORE TRIAL OPERATION" in this chapter.)
Communication port error	Check the operation through a self-diagnosis test.	
No data can be written in any PLC devices.	The "Write Disabled" mode is set for PLC.	Set the "Write Enable" mode for PLC.
No data can be written in a specific PLC device.	Access is made to an invalid device.	Change the device to an available device.
No data can be written in a specific device.	Data is written in a "write-disabled" device (input device, etc.).	Change the device to a "write-enabled" device.

## 4.2 Communication Error Codes

If an error display is arranged on the object screen when the screen is created, detected errors are displayed on the display.



**In case of a communication error, the operation is continued. The RAS output and the parallel output are not turned off at this time.**

Message	Error Code	Description	Corrective Action
Serial communication error	2000   2255	Destination error. The destination error code is displayed in the lower 3 digits(CH1).	Take a proper corrective action according to the displayed error code.
	2300   2555	Destination error. A value of destination error code + 300 is displayed in the lower 3 digits (CH2).	
	2600   2855	Destination error. A value of destination error code + 600 is displayed in the lower 3 digits (CH3).	
	2901	Parity error (CH1)	Check if the communication parameters match with those of the remote device.
	2902	Overrun error (CH1)	
	2903	Framing error (CH1)	
	2904	Received data error (CH1)	Check the format of received data.
	2905	Time-out error (CH1)	Check the following items: <ul style="list-style-type: none"> <li>• Communication cable</li> <li>• Remote device status</li> <li>• Time-out set value</li> <li>• Link unit setting</li> </ul>
	2931	Parity error (CH2)	Same as CH1
	2932	Overrun error (CH2)	
	2933	Framing error (CH2)	
	2934	Received data error (CH2)	
	2935	Time-out error (CH2)	
	2961	Parity error (CH3)	Same as CH1
	2962	Overrun error (CH3)	
	2963	Framing error (CH3)	
	2964	Received data error (CH3)	
	2965	Time-out error (CH3)	

**Note:** CH1 means RS-232C, CH2 means RS-232C (option only for GC56), and CH3 means RS-485.

Note 1: Error codes from PLC are converted as shown below in this system during communications with a Mitsubishi PLC (QnA), Hitachi or Toshiba PLC.

## Mitsubishi PLC (QnA)

OIP's error code (Decimal)	QnA's error code (Hex.)	OIP's error code (Decimal)	QnA's error code (Hex.)	OIP's error code (Decimal)	QnA's error code (Hex.)	OIP's error code (Decimal)	QnA's error code (Hex.)
0	4000H	39	4060H	78	409FH	117	7E40H
1	4001H	40	4061H	79	40A0H	118	7E41H
2	4002H	41	4062H	80	40A1H	119	7E42H
3	4003H	42	4063H	81	40A2H	120	7E43H
4	4004H	43	4064H	82	40A3H	121	7E44H
5	4005H	44	4065H	83	40A4H	122	7E47H
6	4006H	45	4066H	84	40A5H	123	7E4FH
7	4007H	46	4067H	85	40A6H	124	7E50H
8	4008H	47	4068H	86	40B0H	125	7E51H
9	4010H	48	4069H	87	40B1H	126	7E52H
10	4011H	49	406AH	88	40B2H	127	7E53H
11	4021H	50	4070H	89	40B3H	128	7E54H
12	4022H	51	4080H	90	4A00H	129	7E55H
13	4023H	52	4081H	91	4A01H	130	7E57H
14	4024H	53	4082H	92	4A02H	131	7E58H
15	4025H	54	4083H	93	4B00H	132	7F21H
16	4026H	55	4084H	94	7103H	133	7F22H
17	4027H	56	4085H	95	7140H	134	7F23H
18	4028H	57	4086H	96	7142H	135	7F24H
19	4029H	58	4087H	97	7143H	136	7F40H
20	402AH	59	4088H	98	7144H	137	7F41H
21	402BH	60	4089H	99	7145H	138	7F42H
22	402CH	61	408AH	100	7146H	139	7F67H
23	4030H	62	408BH	101	7147H	140	7F68H
24	4031H	63	4090H	102	7148H	141	7F69H
25	4032H	64	4091H	103	714AH	142	F000H to FFFFH
26	4033H	65	4092H	104	714EH		
27	4040H	66	4093H	105	7151H		
28	4041H	67	4094H	106	7155H		
29	4042H	68	4095H	107	7160H		
30	4043H	69	4096H	108	7167H		
31	4044H	70	4097H	109	7168H		
32	4045H	71	4098H	110	7169H		
33	4046H	72	4099H	111	716DH		
34	4050H	73	409AH	112	716EH		
35	4051H	74	409BH	113	7170H		
36	4052H	75	409CH	114	7171H		
37	4053H	76	409DH	115	7172H		
38	4054H	77	409EH	116	7173H		





## Hitachi PLC (H series)

Response Command	Error Code	Description
NACK command	00	Dummy
	01	Parity error
	02	Sum error
	03	Framing error
	04	Overrun error
	05	Protocol error
	06	ASCII error
	07	Receive buffer error
	08	Receive time-over
Response command "05H"	20	Busy
Response command "01H"	21	Undefined task code
	22	Undefined function selection code
	24	Address error
	25	Step/word count error
	26	I/O code error
	27	I/O No. error
	28	Data written over memory capacity.
	30	Memory size over
Response command "08H"	40	Network error
Response command "03H"	41	ROM memory error
	42	Unmatch with parameter area
	43	Occupied by READ
	44	Occupied by WRITE
	45	Debugging from another station
	46	4 stations occupied by READ
	47	Self-station not occupy CPU
	48	Another station occupy CPU
	50	RAM memory error
	51	CPU running
	52	Operation error
	53	Program absent
	54	Task code combination error
	55	Program error

## Toshiba PLC (EX series)

Response Command	Error Code	Description
Computer link error status	01	Command error
	02	Format error
	03	Check sum error
	04	End code error
	05	Text over
	08	Time-out 1
PLC error status	11	END command absent
	12	PAIR command illegal
	13	Program error
	14	Memory full error
	15	Page/circuit No. illegal
	16	Mode unmatched
	17	PROM write error
	18	Operand error
	19	Register No./size error
	20	I/O reference error
	21	I/O response error
	22	Transmission error
	23	Type unmatched
24	Page full	

---

# **CHAPTER II**

## **CONNECTION TO A PLC**

## 1. OUTLINE

The OIP can be connected to a PLC to perform data read/write operations directly on the devices of the PLC using a direct access method. No ladder programs are therefore required for communication.

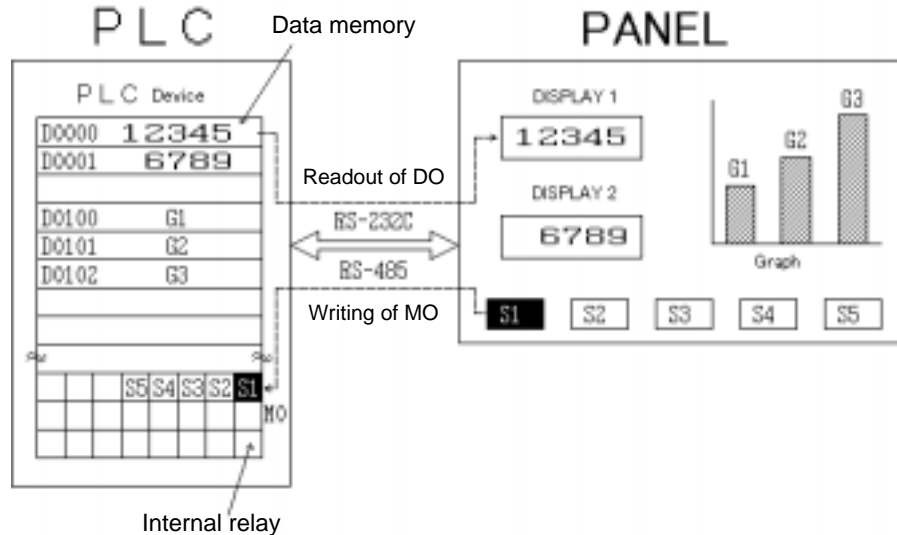

The OIP communicates with the PLC screen by screen.

The OIP has two types of screens: Local screens, and global screens.

When the PLC device accesses a local screen, it communicates with the OIP only when the screen is displayed. When it accesses a global screen, it communicates with the OIP whenever necessary, regardless of the type of a displayed screen.

The maximum number of PLC devices that can be connected with a single screen of the GC5x Series is increased to 16000, while only 2048 PLC devices can be connected with a single screen of the GC Series. (Each 16000 devices can be connected with either a local screen or global screen.)

## 2. NOTES FOR USE

---

Upon using this system, keep the following in mind.

### **WARNING**

- |   |
|---|
| <p>1) <b>Do not output data directly to any external output device of PLC. Data is output to such an external device directly regardless of the interlock status of the ladder circuit. Since such an external device is used for driving a motor, etc., it is very dangerous to do so.</b></p> |
|---|



Type and notation of devices differ among makers. Since OIP does not support all devices, select an appropriate device carefully in reference to “Station Numbers and Devices” of each maker.

The maximum address range is set for each device in this system. Thus, the address range may become smaller for some PLC types. Check the address range carefully in reference to the instruction manual of each PLC type.

If the set range is exceeded, it is regarded as an error in communications.

It is recommended to set consecutive addresses for a device arranged on a screen to improve the efficiency of communications. If addresses are dispersed, the number of communications is increased. As a result, display responses may be delayed significantly.

Communications are made for individual screens. Note that when a screen is changed to another, the communication on the previous screen is stopped.

No terminal resistor is incorporated in this system. If RS-422/485 is to be used for communications, an external terminal resistor should be attached to this system. An external terminal resistor pin is provided on the connector.

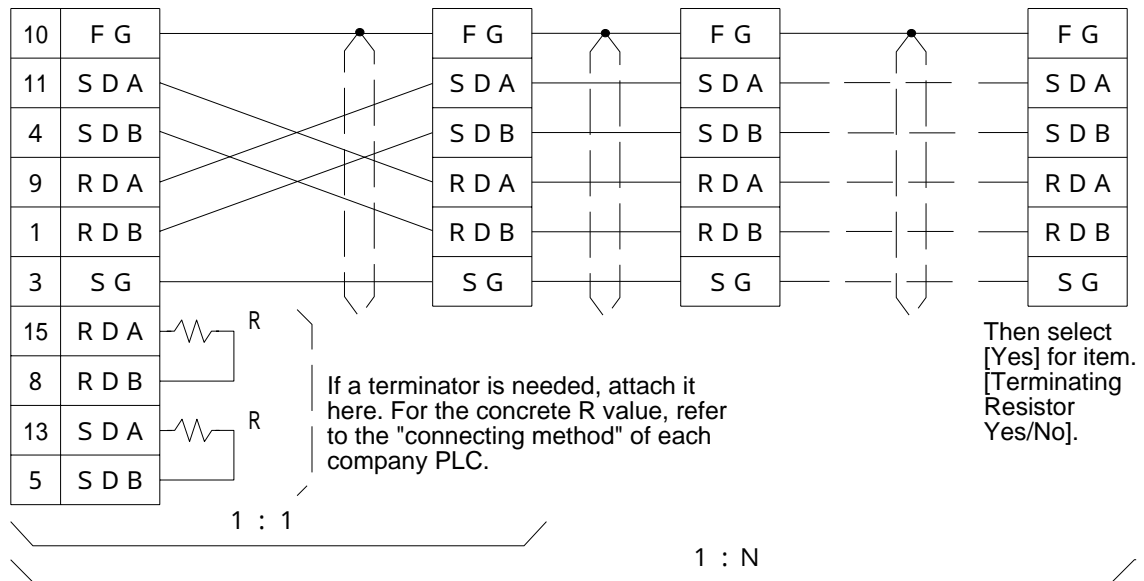

### 3. SETTING PLC MANUFACTURER NAME AND MODEL NUMBERS



Before connecting a PLC to the OIP, users must activate the screen-creating software Screen Creator 5 and then set the model and protocol of the PLC during creation of a screen. If a screen to be used for the PLC is created without a model or protocol being set, an error will occur during creation of the data to be downloaded.

The setting procedure is described below.

Select "Property of project (P)" on the "Project (P)" menu.

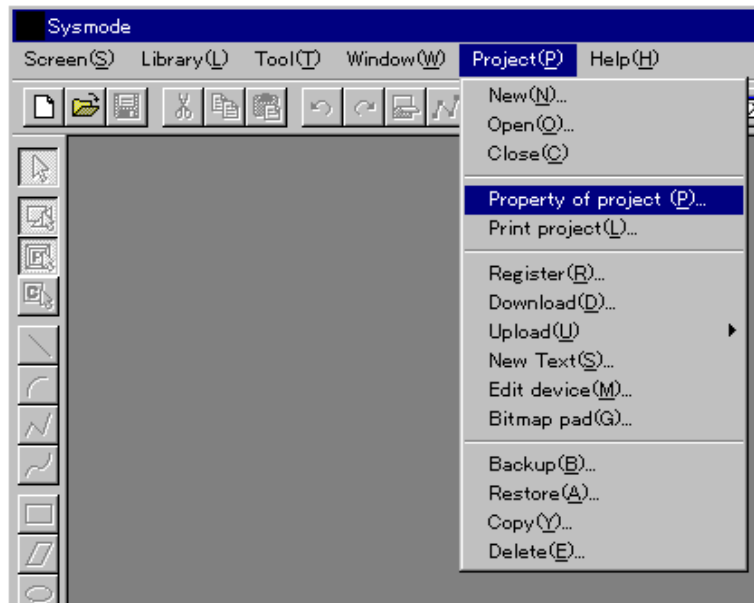

The Project Properties window appears.

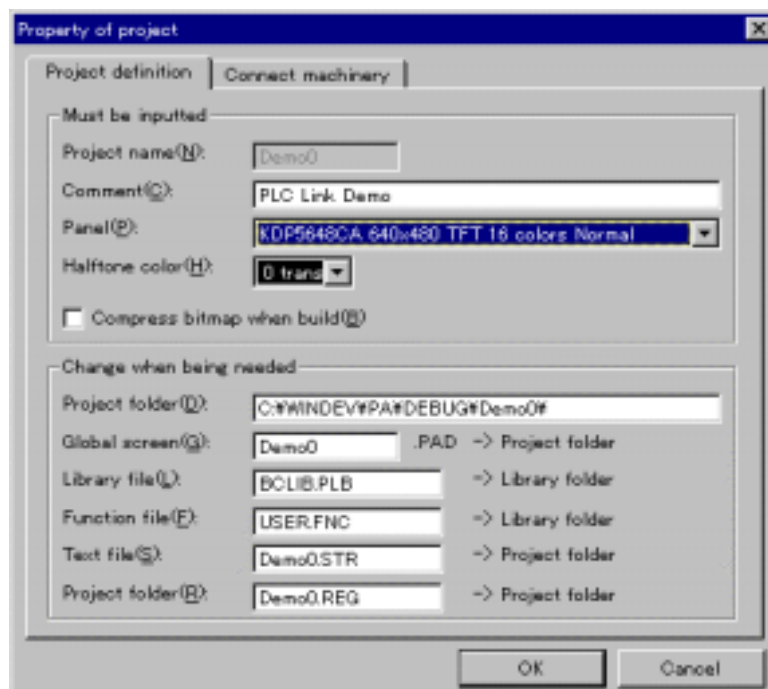



Then, click on the “Connect Machinery” tag. The Connection Equipment Setup window appears.

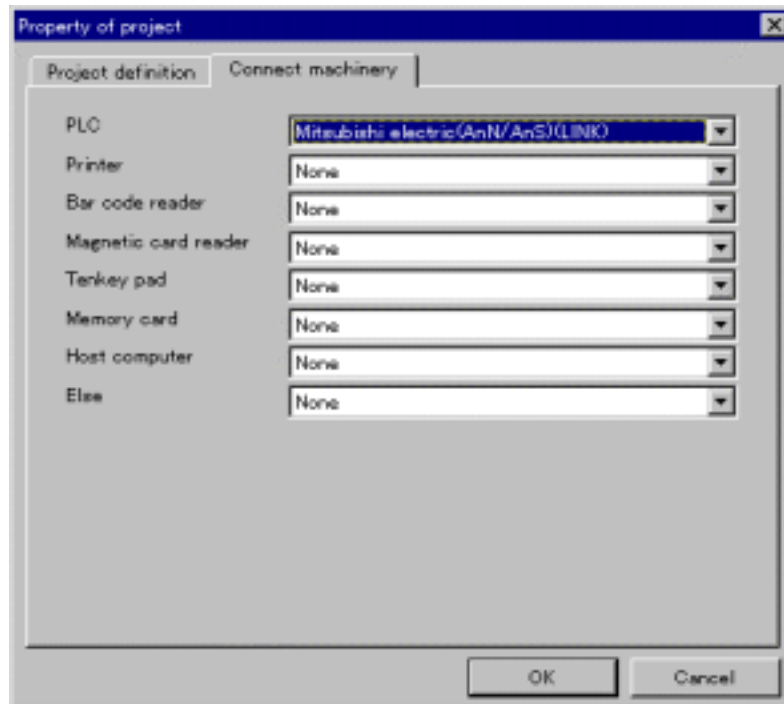

Click on the “ ” mark of the PLC. The PLC list is displayed. Select a PLC to be used.

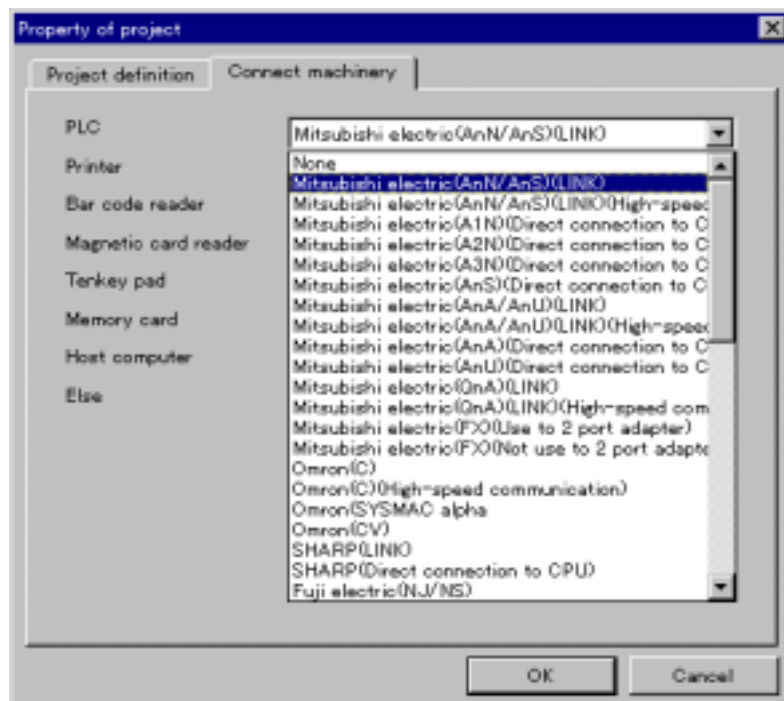

On completion of setting, click on “OK”. The Project Properties window is closed.

To cancel setting, click on “Cancel”.

## 4. SETTING DEVICE NAMES

This section describes the procedures of setting the PLC devices corresponding to the indicators and switches.

Open the “Part Properties” window of the part for which a device is to be set.

Method 1: Move the mouse cursor to the part for which a device is to be set, and double-click the left mouse button.



**Note that the Edit Contents window opens if the left mouse button is double-clicked at the upper left corner of the part where the mouse cursor changes into the [P] mark.**

Method 2: Move the mouse cursor to the part for which a device is to be set, and click the left mouse button(select part), and select “Edit (E)” on the main menu, then select “Change Attributes/ Properties (E)”.

Method 3: Move the mouse cursor to the part for which a device is to be set, and click the left mouse button(select part), and select “Tool (T)” on the main menu, select “Browse List (B)”, then select the part for which a device is to be set. When the part is selected, click the right mouse button to open the pop-up menu, then select “Change Attributes/ Properties (E)”.

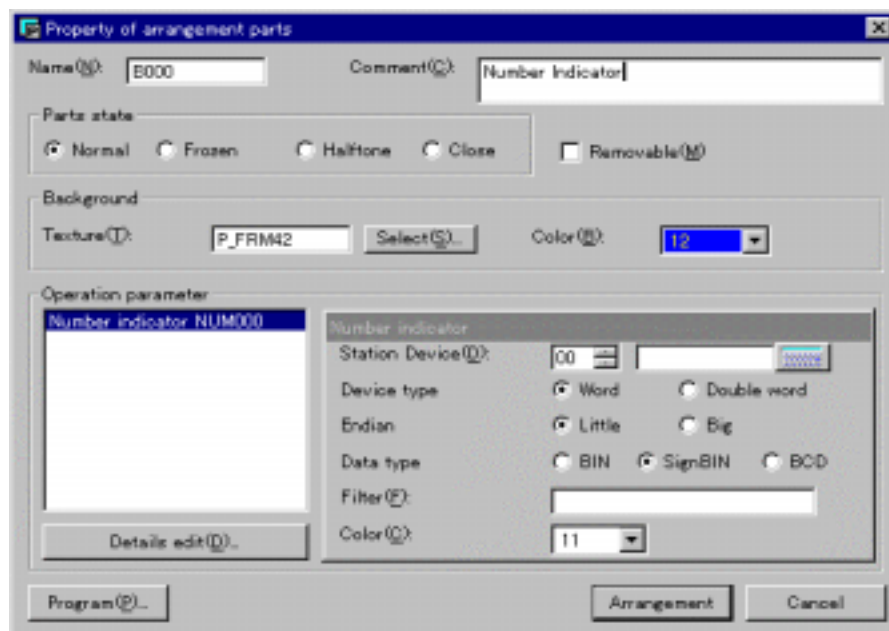

Input the machine ID number and device name of the PLC in “Station Device (D)” in the Operation Parameters field.

On completion of setting, click on the left mouse button at the OK position.

To cancel setting, click the left mouse button at “Cancel”.



- The type of device and the method of expressing the device type vary from manufacturer to manufacturer. Also, not all devices are supported. Before setting a device type, therefore, see “Usable station numbers and devices”.
- Only the maximum address data ranges that can be set for each device are listed in this manual. For some specific models, therefore, values that can be actually set may be smaller than those listed here. Check against the operating manual of the model to be used. If data overstepping the required range is set, an error will occur during communication.
- For improved communication efficiency, KOYO recommends that addresses for devices of the same type should be set in succession on one screen. Use of different device addresses correspondingly increases the frequency of communication and may thus extremely delay the response of display.

## 5. SETTING COMMUNICATION PARAMETERS

A PLC can be connected to all serial ports. Select the system-setting mode of the OIP, and set the parameters for the ports that you want to use.

Refer to Section 3, "BEFORE TRIAL OPERATION" of Chapter I, for further details of parameter setting.

### 1) Communication type

Select PLC as the communication type.

If PLC has already been set as the communication type for other ports, this parameter cannot be set for the ports that you are going to use. In that case, set PLC for the intended ports only after changing the current setting to either NOT USED or other units.

### 2) Other parameters

Set other communication parameters according to the communication specifications of the model to be connected.



**As listed below, the defaults of parameters other than the communication type parameter are preset for each model.**

**To modify these presettings, refer to the operating manual of the link unit of the companies' PLC to be used.**

Manufacturer name	Transmission rate	Parity	Stop bits	Data length	Retry count	Timeout time (sec)	Xon/off	Sum check
Mitsubishi (FX Series)	9600	EVEN	1	7	1	3	No	Yes
Mitsubishi (Direct connection to CPU)	9600	ODD	1	8	3	3	No	Yes
Mitsubishi (Other than above)	9600	EVEN	1	8	1	3	No	Yes
Omron	9600	EVEN	1	8	1	3	No	Yes
Fuji	9600	EVEN	1	8	1	3	No	Yes
Hitachi	9600	EVEN	1	8	1	3	No	Yes
Sharp	9600	EVEN	2	7	1	3	No	Yes
Toyota Koki	9600	EVEN	1	7	1	3	No	Yes
Yasukawa	9600	EVEN	1	8	1	3	No	Yes
Yokogawa (CPU No. 1 - 4)	9600	EVEN	1	8	1	3	No	Yes
Yokogawa (CPU No. Variable)	9600	EVEN	1	8	1	3	No	No
Matsushita	9600	EVEN	1	8	1	3	No	Yes
Matsushita	9600	EVEN	1	8	1	3	No	Yes
Toshiba (EX Series)	9600	EVEN	2	8	1	3	No	Yes
Toshiba (T Series)	9600	ODD	1	8	1	3	No	Yes
Yamatake-Honeywell	9600	EVEN	1	8	1	3	No	Yes
Toyo	9600	NONE	1	8	1	3	No	Yes
Allen-Bradley	19200	EVEN	1	8	1	3	No	Yes

## 6. CONNECTION OF SEVERAL OIP UNITS (M:N COMMUNICATION)

It is possible to connect several OIP units (GC5x Series) with one or more PLC units through CH3 RS-422/RS-485 port without using a multi-panel unit as shown below:

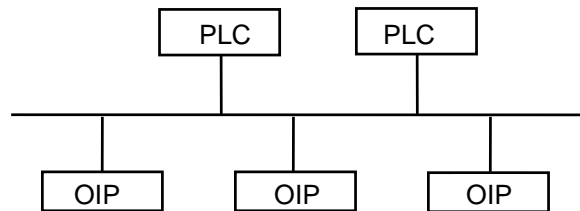

Three-wired half-duplex communication is executed in this connection. Thus, the PLC units should support three-wired halfduplex communication.

It is confirmed that the PLC units of the manufacturers shown below supports three-wired half-duplex communication.

- MITSUBISHI (AnN, AnS, AnA, and AnU: Direct CPU connection is not supported.)
- OMRON
- SHARP
- FUJI
- YOKOGAWA
- TOYOTA KOKI

\* Three-wired half-duplex communication is enabled through the RS-485 port on each model.

To validate the function of connecting several OIP units, open the system mode menu on the OIPs, then select the following in the shown order:

“System Setup” “RS-485 Setup” “Detail Setup”

\* See section 3-2 “Communication Parameter Setting”.

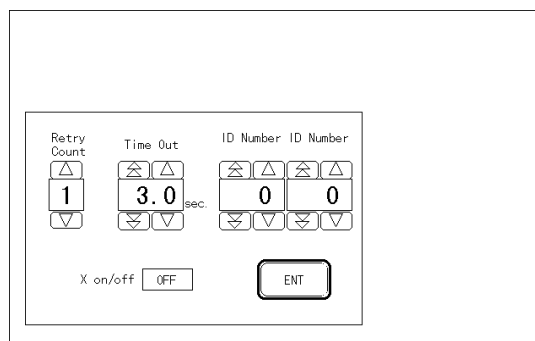

Set the station number of the OIP on which this setting is done in “Station No.” and the station number of the destination OIP in “Next Station No.”. In other words, set the station number of the second OIP in “Next Station No.” of the first OIP, the station number of the third OIP in “Next Station No.” of the second OIP, and so forth. When “M” OIP units are connected, set the station number of the first OIP in “Next Station No.” of the Mth OIP.



- When a number other than 0 is set in “Next Station No.,” the OIP recognizes that several OIP units are connected. Unless the station number and the next station number are set properly, the OIP units fail to function properly. Be sure to set 0 in “Next Station No.” when only one OIP is connected.
- Do not assign a station number of a PLC to an OIP unit. The range of the station numbers which can be assigned to OIP units depends on the PLC units to be connected. For details, refer to the description about connection with PLC units.
- When several OIP units are connected, the “master station” always exists, and the master OIP always starts communication. The “master station number” differs with PLC units. For details, see “Master Station Number” in the description about connection with PLC units.

Setting example: Connection with MITSUBISHI PLC units

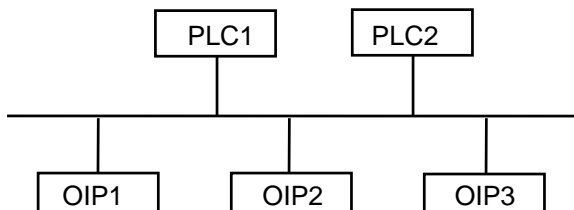

	Station No.	Next station No.
PLC1	00	-
PLC2	01	-
OIP1 (Master station)	255	02
OIP2	02	03
OIP3	03	255



- The master station number is not 255 according to the types of PLC units connected. For the master station number applicable to PLC units connected, refer to the description about connection with PLC units.

## 7. LIST OF CONNECTABLE PLC TYPES

This section will show the list of PLC types (makers) connectable to the GC5x series OIP, the list of link units, and the list of devices registered for “Environment Setting” of Screen Creator 5.



- The Screen Creator 5 “Project Property” column shows PLC types to be selected for the devices registered on the “Project Property”.  
The PLC selection differs among connection forms and protocols even for the same type PLC.
- The “MPU” column shows whether or not the PLC can be connected to a multi-panel unit (???21NU-1) of our company.
- The “M:N” column shows whether or not the PLC can be connected to two or more OIPs which do not employ our multipanel.

	Series Name	Object Type	Link Unit	Remark	Screen Creator 5 Environment Setting	MPU	M:N	
Mitsubishi	MELSEC-AnN MELSEC-AnS	A1N, A2N, A3N	AJ71C24-S6 AJ71C24-S8 AJ71UC24		MITSU (AnN/AnS)(LINK) MITSU (AnN/AnS)(LINK) (High-speed communication)	*1	*3	
		A0J2, A0J2H	A0J2-C214S1					
		A1S, A2S, A1SJ	A1SJ71C24 A1SJ71UC24					
		A1N	Direct connection to CPU		MITSU (A1N)(Direct connection to CPU)	x	x	
		A2N	Direct connection to CPU		MITSU (A2N)(Direct connection to CPU)			
		A3N, A1SH, A1SJH	Direct connection to CPU		MITSU (A3N)(Direct connection to CPU)			
		A0J2H	Direct connection to CPU		MITSU (AnS)(Direct connection to CPU)			
		A1S	Direct connection to CPU					
		MELSEC-AnA MELSEC-AnU	A2US, A2USH	A1SJ71C24 A1SJ71UC24		MITSU (AnA/AnU)(LINK) MITSU (AnA/AnU)(LINK) (High-speed communication)	*1	*3
			A2A, A3A A2U, A3U, A4U	AJ71C24(-S6/S8) AJ71UC24				
			A2US	Direct connection to CPU		MITSU (AnU)(Direct connection to CPU)	x	x
			A2A, A3A	Direct connection to CPU		MITSU (AnA)(Direct connection to CPU)		
			A2U, A3U, A4U	Direct connection to CPU		MITSU (AnU)(Direct connection to CPU)		
		MELSEC-QnA	Q2A, Q3A, Q4A, Q4AR	AJ71QC24(-R2/R4)		MITSU (QnA)(LINK) MITSU (QnA)(LINK) (High-speed communication)	*1	x
		Q2AS	A1SJ71QC24 A1SJ71QC24-R2					
	MELSEC-FX	FX0, FX1, FX2 FX2C, FX2N	Direct connection to CPU		MITSU (FX) (2-port adaptor unused) MITSU (FX) (2-port adaptor used)		x	
OMRON	SYSMAC C	C500, C500F C1000H(F), C1000F C2000, C2000H	C500-LK201-V1 C500-LK203	The C1000HF cannot be connected to the LK201-V1.	OMRON (C) OMRON (C)(High-speed communication) OMRON (SYSMAC )	*1	*3	
		C200H, C200HS C20H, C28H C40H, C60H	C200H-LK201-V1 C200H-LK202-V1	Only when C200H I/O is expanded for C**H				
		C120, C120F, C200 C200H, C500, C500F C1000H, C1000F C2000, C2000H C20H, C60H	C120-LK201-V1 C120-LK202-V1					
		C20P(F), C28P(F) C40P(F), C60P(F)	C20-LK201-V1 C20-LK202-V1					
		C200HS	CPU unit link I/F					

	Series Name	Object Type	Link Unit	Remark	Screen Creator 5 Environment Setting	MPU	M:N
					OMRON (SYSMAC )	*	*
		C200HX, C200HG, C200HE	CPU unit link I/F			1	3
	SYSMAC CQM1	CQM1-CPU21/4*	CPU unit link I/F		OMRON (C)		x
	SYSMAC CPM1	CPM1	CPM1-CIF01 CPM1-CIF11		OMRON (C)(High-speed communication) OMRON (SYSMAC )		x
	SYSMAC CV	CV500, CV1000 CV2000, CVM1	CV500-LK201 CPU unit link I/F		OMRON (CV)		*3
Fuji	FLEX-PC	NJ	NJ-RS2, NJ-RS4		FUJI (NJ/NS)	x	*3
		NS	NS-RS1				
		NB1, NB2, NB3	NB-RS1-AC				
		NJ-T, NS-T	NJ-RS1, NJ-RS2 NJ-RS4		FUJI (NJ-T/NS-T)	x	x
		NJ-T, NJ-JM, NS-T	CPU loader connector		FUJI (Loader command)	x	x
		NJ-JM	CPU connector link	(Terminal strip)	FUJI (Computer link)	x	x
	MICREX-F	F70, F70S	NC1L-RS2, NC1L-RS4		FUJI (MICREX-F)		*3
	F80H, F120H F120S, F140S F15*S, F250	FFU120B					
	T link	FFK100A-C10 FFK120A-C10	A memory cassette FMC312A is needed.				
Hitachi	HIDIC H	H-302 H-702 H-2002	COMM-H, COMM-2H		HITACHI (H)(LINK) HITACHI (H)(Direct connection to CPU) HITACHI (H)(LINK) (Non-occupancy) HITACHI (H)(Direct connection to CPU) (Non-occupancy)	x	
			Direct connection to CPU		HITACHI (H)(Direct connection to CPU)		
			Remote I/O module REM-LOH, OREM-LH		HITACHI (H)(Direct connection to CPU) (Non-occupancy)		
	H-300 H-700 H-200	COMM-H, COMM-2H		HITACHI (H) HITACHI (H)(Direct connection to CPU)			
		Direct connection to CPU		HITACHI (H)(Direct connection to CPU)			
		Remote I/O module REM-LOH, OREM-LH					
	H-20, H-28 H-40, H-64 HL-40, HL-64 H-200, H-252C	Direct connection to CPU		HITACHI (H)(Direct connection to CPU)			
Sharp	New satellite JW	JW20, JW70, JW100	CPU unit link I/F		SHARP (Direct connection to CPU)	*3	
		JW50, JW50H, JW70 JW100	ZW-10CM		SHARP (LINK)		
		JW20, JW20H, W30H	JW-21CM				
Toyota Koki	TOYOPUC	PC1	CPU unit link I/F		TOYOTA KOKI (PC1)	x	x
		PC2, L2	TPU-5174, TPU-5138 TLU-2695, TLU-2769		TOYOTA KOKI (PC2) TOYOTA KOKI (PC2)(High-speed communication)	*1	*3
		PC2J	THU-2755, THU-5139 THU-2927			*2	
		PC2J16, PC2JC	CPU unit link I/F				
		PC3J	CPU unit link I/F			TOYOTA KOKI (PC3)	x





7. LIST OF CONNECTABLE PLC TYPES

	Series Name	Object Type	Link Unit	Remark	Screen Creator 5 Environment Setting	MPU	M:N
Yasukawa	Memocon-SC	GL40S	JAMSC-IF41A JAMSC-IF61 JAMSC-IF612		YASUKAWA (ASCII) YASUKAWA (RTU)		×
		GL60S, GL60H GL-70H	JAMSC-IF60(IOP) JAMSC-IF61(COMM) JAMSC-IF612				
		GL120, GL130	JAMSC-120NOM26100 JAMSC-120NOM27100				
		U84, U84J	JAMSC-C8110				
		U84S	JAMSC-C8610				
		CP-9200SH	CP-2171F				
	Inverter	VS-616G5	SI-K2		YASUKAWA (Inverter)		
Yokogawa	FACTORY ACE	FA-500	LC01-0N LC02-0N		YOKOGAWA (CPU_No.*) YOKOGAWA (CPU_No.*)	*1	*3
		FA-M3	F3LC01-1N F3LC11-1N F3LC11-2N		(High-speed communication) YOKOGAWA (CPU NO. VARIABLE) YOKOGAWA (CPU NO. VARIABLE)		
		FA-M3 (SP-25,SP-35)	CPU port		(High-speed communication)		
	Temperature adjusting meter	UT-2400 UT-2800 UT-350	Body		YOKOGAWA (CPU NO. VARIABLE), YOKOGAWA (CPU NO. VARIABLE) (High-speed communication)	*1	×
Matsushita	MEWNET	FP1-C24C, C40C FP1-C56C, C72C	CPU unit link I/F		MATSUSHITA (FP)		×
		FP3	AFP3462(C.C.U)				
		FP5	AFP5462(C.C.U)				
		FP10	AFP5462(C.C.U)				
		FP-M	CPU board link I/F				
Matsushita	Panadac	Panadac 7000	GCP-001		MATSUSHITA (Panadac7000)	×	×
Toshiba	PROSEC	EX100, EX2000	CPU unit link I/F		TOSHIBA (EX)		×
		T2, T3, T3H	CPU unit link I/F		TOSHIBA (T)		
Yamatake	FA controller MA500	MA500	CIM3 (510-0042) CNM7 (510-00s31) SLM7 (511-9937) SIOM7 (511-9938)		YAMATAKE (MA500)		×
Keyence	KZ series	KZ-300	KZ-L2		OMRON (C)		×
		KZ-A500	KZ-L10		MITSU (AnA,AnU)(LINK) MITSU (AnA,AnU)(LINK) (High-speed communication) MITSU (AnN/AnS)(LINK) MITSU (AnN/AnS)(LINK) (High-speed communication)		×
Toyo	Digital controller	μ-GPCH	TPC-151 TPC-161		TOYO (μ-GPCH)		×
A-B	SLC-500	SLC-500	1747-KE		AB(SLC500)	×	×
			1770-KF3				
			SLC-5/03 CPU unit 232C port				
			SLC-5/04 CPU unit 232C port				

- \*1 If a device indicated as (High-speed communication) is selected in Environmental Setting, neither our Multi-Panel or M:N connecting is available.
- \*2 Available in four-wired connection only.s
- \*3 Only devices with RS-485 ports are available.



# 1. PLC Supplied by Mitsubishi

## 1.1 AnN, AnS (for link unit)

Select [Mitsubishi (AnN/AnS) (LINK)] from the connection devices of the “Project Property” on Screen Creator 5. “Mitsubishi (AnN/AnS) (LINK) (High-speed communication)” provides high-speed communication, since it registers as many devices as possible in the PLC. Select “Mitsubishi (AnN/AnS) (LINK)” when the multi-panel unit ???21NU-1 is used or M:N connection is performed. For connectable PLC types and link units, refer to Section 2, “List of Connectable PLC Types” of Chapter II.

### 1) Setting a link unit and notes for use



- Protocol type: Set type 4 as the control protocol.
- Sum check: Fix it at “ON”.
- Write Enable/Disable during running: Set “Enable”.
- The number of devices from/in which data can be read/written at a time is as shown below.
 

Read/write:	128 ports (bit devices)
	64 ports (word devices)

### 2) Usable station numbers and devices

Station numbers (PLC)

- 00 to 31 (Decimal notation)

OIP ID number in M:N connection

- 00 to 255 (Decimal notation)
- Set the OIP master ID number to 255.
- The OIP ID number must not be the same as the PLC ID number.

Devices

- Bit devices

Device name	Range
External input relay	X0000 - X07FF
External output relay	Y0000 - Y07FF
Internal relay	M0000 - M2047
Special internal relay	M9000 - M9255
Latch relay	L0000 - L2047
Step relay	S0000 - S2047
Link relay	B0000 - B03FF
Annunciator	F0000 - F0255
Timer (contact)	TS000 - TS255
Timer (coil)	TC000 - TC255
Counter (contact)	CS000 - CS255
Counter (coil)	CC000 - CC255

- Word devices

Device name	Range
Timer (current value)	TN000 - TN255
Counter (current value)	CN000 - CN255
Data register	D0000 - D1023
Special data register	D9000 - D9255
Link register	W0000 - W03FF
File register	R0000 - R8191

### 3) OIP connection

RS-232C (in the case that DSUB-9P is used on the link unit side)

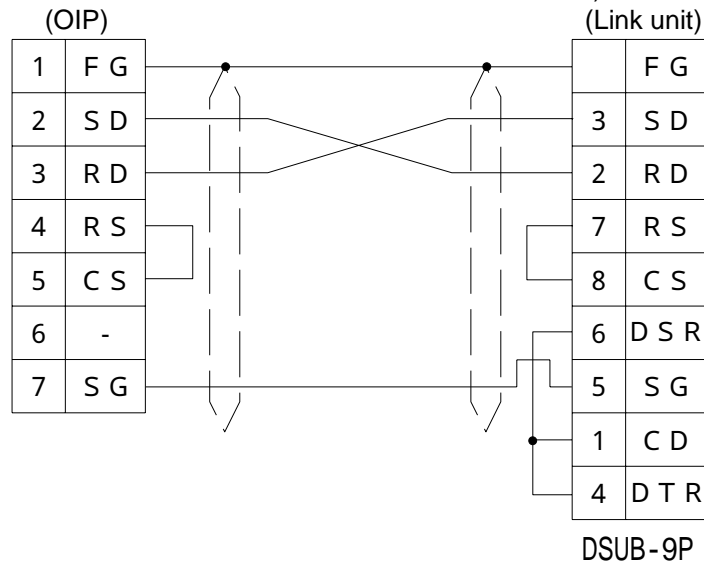

RS-232C (in the case that DSUB-9P is used on the link unit side)

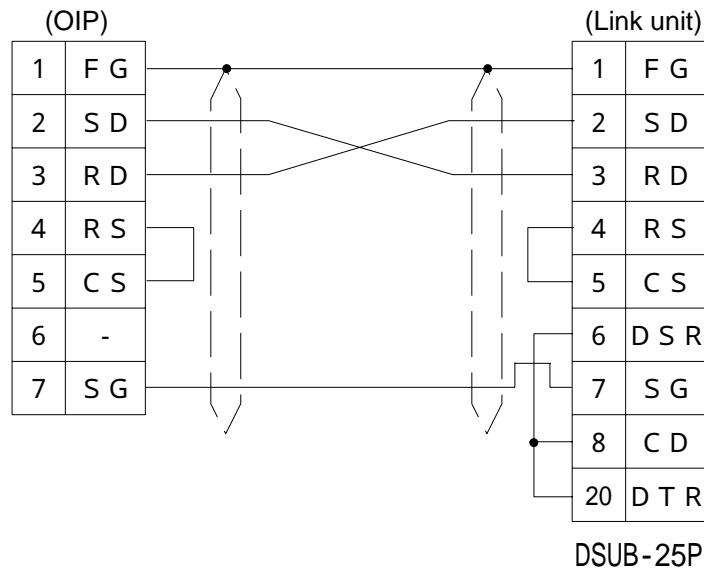

RS-422/RS-485 [1:1, 1:N]

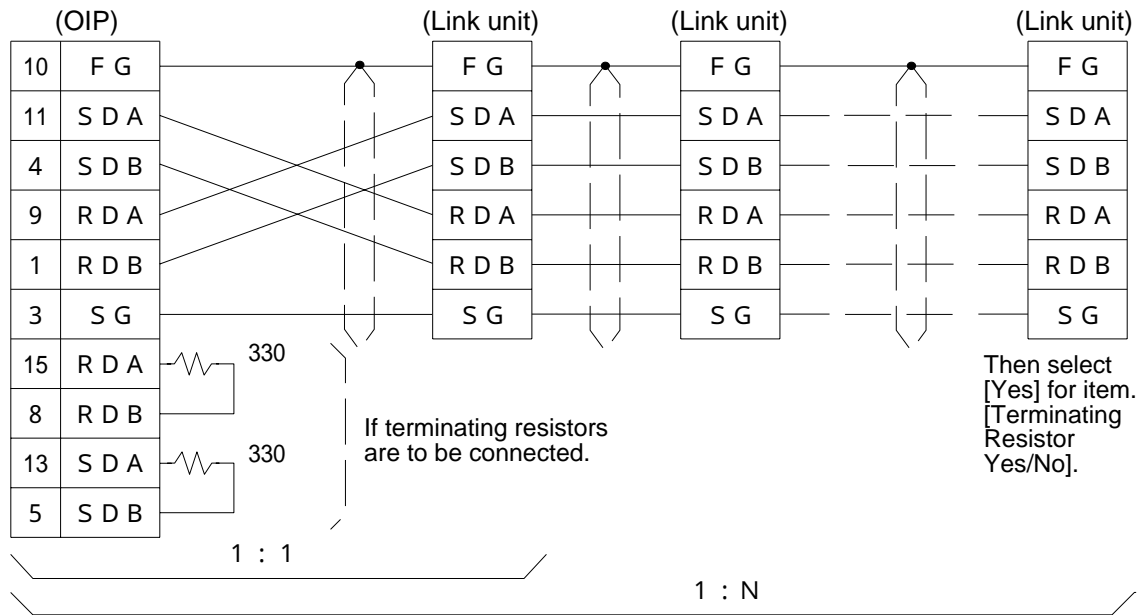

RS-422/RS-485 [M: N]

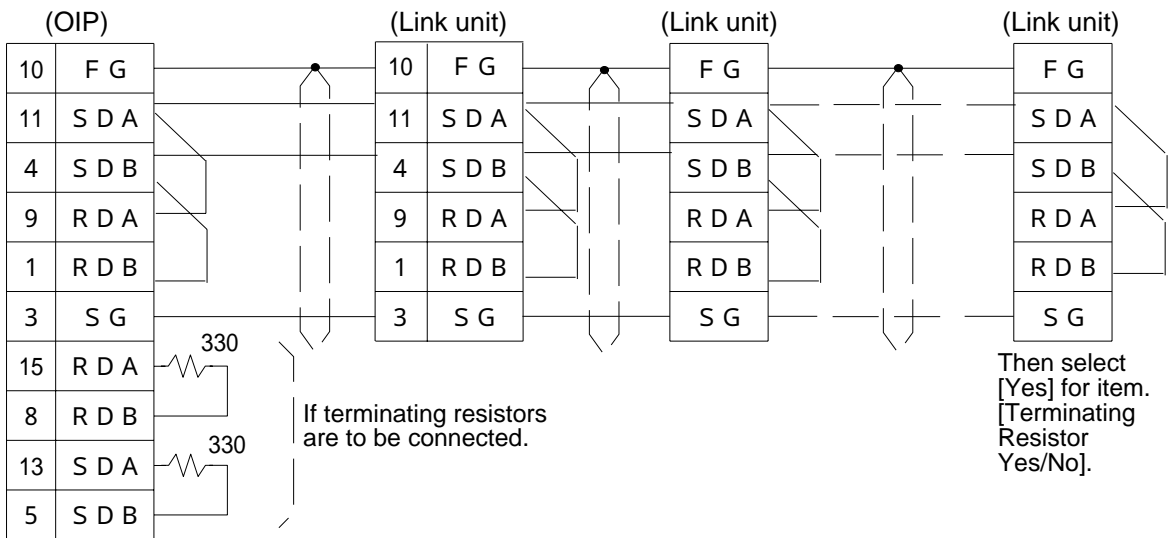

## 1.2 AnA, AnU, AnUS (for link unit)

Select [Mitsubishi (AnA/AnU) (LINK)] from the connection devices of the “Project Property” on Screen Creator 5. “Mitsubishi (AnA/AnU) (LINK) (High-speed communication)” provides high-speed communication, since it registers as many devices as possible in the PLC. Select “Mitsubishi (AnA/AnU) (LINK)” when the multi-panel unit ???21NU-1 is used or M:N connection is performed. For connectable PLC types and link units, refer to Section 2, “List of Connectable PLC Types” of Chapter II.

### 1) Setting a link unit and notes for use



- Command: AnA and AnU dedicated commands are used.
- Protocol type: Set type 4 as the control protocol.
- Sum check: Fix it at “ON”.
- Write Enable/Disable during running: Set “Enable”.
- The number of devices from/in which data can be read/written at a time is as shown below.
 

Read/write:	128 ports (bit devices)
	64 ports (word devices)

### 2) Usable station numbers and devices

Station numbers (PLC)

- 00 to 31 (Decimal notation)

OIP ID number in M:N connection

- 00 to 255 (Decimal notation)
- Set the OIP master ID number to 255.
- The OIP ID number must not be the same as the PLC ID number.

Devices



**This system is designed so that devices that are not supported at present can also be declared to cope with the system expansion in the future. When any devices are to be used, check each device range of your PLC carefully.**

- Bit devices

Device name	Range
External input relay	X000000 - XFFFFFFF
External output relay	Y000000 - YFFFFFFF
Internal/Special internal relay	M000000 - M999999
Latch relay	L000000 - L999999
Step relay	S000000 - S999999
Link relay	B000000 - BFFFFFFF
Annunciator	F000000 - F999999
Timer (contact)	TS00000 - TS99999
Timer (coil)	TC00000 - TC99999
Counter (contact)	CS00000 - CS99999
Counter (coil)	CC00000 - CC99999

- Word devices

Device name	Range
Timer (current value)	TN00000 - TN99999
Counter (current value)	CN00000 - CN99999
Data/Special data register	D000000 - D999999
Link register	W000000 - WFFFFFFF
File register	R000000 - R999999

### 3) OIP connection

These connections are made in the same way as that stated in subsection 1-1, "AnN, AnS (for link unit)", (see pages II 1-2 and II 1-3).



## 1.3 QnA

Select [Mitsubishi (AnN/AnS) (LINK)] from the connection devices of the “Project Property” on Screen Creator 5. “Mitsubishi (AnN/AnS) (LINK) (High-speed communication)” provides high-speed communication, since it registers as many devices as possible in the PLC. Select “Mitsubishi (AnN/AnS) (LINK)” when the multi-panel unit ???21NU-1 is used.

For connectable PLC types and link units, refer to Section 2, “List of Connectable PLC Types” of Chapter II.

### 1) Setting a link unit and notes for use



- Protocol type: Set type 4 as the control protocol.
- Sum check: Fix it at “ON”.
- Write Enable/Disable during running: Set “Enable”.
- The number of devices from/in which data can be read/written at a time is as shown below.
 

Read/write:	128 ports (bit devices)
	64 ports (word devices)

### 2) Usable station numbers and devices

Station numbers

- 00 to 31 (Decimal notation)

Devices



**This system is designed so that devices that are not supported at present can also be declared to cope with the system expansion in the future. When any devices are to be used, check each device range of your PLC carefully.**

- Bit devices

Device name	Range
Input relay	X000000 - X0FFFFFF
Output relay	Y000000 - Y0FFFFFF
Internal relay	M000000 - M099999
Latch relay	L000000 - L099999
Annunciator	F000000 - F099999
Edge relay	V000000 - V099999
Link relay	B000000 - B0FFFFFF
Step relay	S000000 - S099999
Timer (contact)	TS00000 - TS99999
Timer (coil)	TC00000 - TC99999
Integrated timer (contact)	SS00000 - SS99999
Integrated timer (coil)	SC00000 - SC99999
Counter (contact)	CS00000 - CS99999
Counter (coil)	CC00000 - CC99999
Special relay	SM00000 - SM99999
Special link relay	SB00000 - SB99999
Direct input	DX00000 - DXFFFFFF
Direct output	DY00000 - DYFFFFFF

- Word devices

Device name	Range
Timer (current value)	TN00000 - TN99999
Integrated timer (current value)	SN00000 - SN99999
Counter (current value)	CN00000 - CN99999
Data register	D000000 - D099999
Link register	W000000 - W099999
Special register	SD00000 - SD99999
Special link register	SW00000 - SW99999
Index register	Z000000 - Z099999
File register	R000000 - R099999 ZR00000 - ZR99999

### 3) OIP connection

These connections are made in the same way as that stated in subsection 1-1, "AnN, AnS (for link unit)", (see pages II 1-2 and II 1-3).



**The connection of QnA cannot be made in M:N connection .**

## 1.4 A Series (Direct Connection to CPU)

Communications between OIP and PLC can be made at 1:1 by connecting the dedicated Mitsubishi cable (???10CC-1/\*) to the connector of the object CPU unit peripheral device.

Select the object CPU "Mitsubishi (A\*\*)" (Direct connection to CPU) from the connection devices of the "Project Property" screen of Screen Creator 5.

For connectable CPU types, refer to Section 2, "List of Connectable PLC Types" of Chapter II.

### 1) Notes for use



- Use CH1 as the OIP serial communication port. CH2 and CH3 cannot be used.
- The external input relay (X) can be used for reading, but cannot be used for writing.
- The number of devices from/in which data can be read/written at a time is as shown below.
 

Read:	128 ports (bit devices)/122 ports (word devices)
Write:	1 port (bit devices)/122 ports (word devices)
- Communication parameters
 

Set the communication parameters for OIP as shown below.  
Those parameters are fixed in the CPU unit.

Communication rate:	9600 bps
Parity bit:	ODD
Stop bit length:	1 bit
Data length:	8 bits
- If the object PLC is connected to the CPU directly, the responsibility of switches and displays may become slower than that when the link unit is used at a speed of 19200 bps.

### 2) Usable station numbers and devices

Station number

00 (Set "00" for the station number, although no station number is assigned on the protocol.)

Devices



- If a file register (R) is to be used, the use range should be set on the PLC side.
- External I/O relays (X, Y) can be declared for the maximum range of each type PLC. Check the device range of your PLC when those I/O relays are to be used.

[MELSEC AnN or AnS]

- Bit devices

Device name	Range
External input relay	X0000 - X07FF
External output relay	Y0000 - Y07FF
Internal relay	M0000 - M2047
Special internal relay	M9000 - M9255
Latch relay	L0000 - L2047
Step relay	S0000 - S2047
Link relay	B0000 - B03FF
Annunciator	F0000 - F0255
Timer (contact)	TS000 - TS255
Timer (coil)	TC000 - TC255
Counter (contact)	CS000 - CS255
Counter (coil)	CC000 - CC255

- Word devices

Device name	Range
Timer (current value)	TN000 - TN255
Counter (current value)	CN000 - CN255
Data register	D0000 - D1023
Special data register	D9000 - D9255
Link register	W0000 - W03FF
File register	R0000 - R8191

[MELSEC AnA]

- Bit devices

Device name	Range
External input relay	X000000 - X0007FF
External output relay	Y000000 - Y0007FF
Internal relay	M000000 - M008191
Special internal relay	M009000 - M009255
Latch relay	L000000 - L008191
Step relay	S000000 - S008191
Link relay	B000000 - B000FFF
Annunciator	F000000 - F002047
Timer (contact)	TS00000 - TS02047
Timer (coil)	TC00000 - TC02047
Counter (contact)	CS00000 - CS01023
Counter (coil)	CC00000 - CC01023

- Word devices

Device name	Range
Timer (current value)	TN00000 - TN02047
Counter (current value)	CN00000 - CN01023
Data register	D000000 - D006143
Special data register	D009000 - D009255
Link register	W000000 - W000FFF
File register	R000000 - R008191

[MELSEC AnU]

- Bit devices

Device name	Range
External input relay	X000000 - X001FFF
External output relay	Y000000 - Y001FFF
Internal relay	M000000 - M008191
Special internal relay	M009000 - M009255
Latch relay	L000000 - L008191
Step relay	S000000 - S008191
Link relay	B000000 - B001FFF
Annunciator	F000000 - F002047
Timer (contact)	TS00000 - TS02047
Timer (coil)	TC00000 - TC02047
Counter (contact)	CS00000 - CS01023
Counter (coil)	CC00000 - CC01023

- Word devices

Device name	Range
Timer (current value)	TN00000 - TN02047
Counter (current value)	CN00000 - CN01023
Data register	D000000 - D008191
Special data register	D009000 - D009255
Link register	W000000 - W001FFF
File register	R000000 - R008191

3) OIP connection

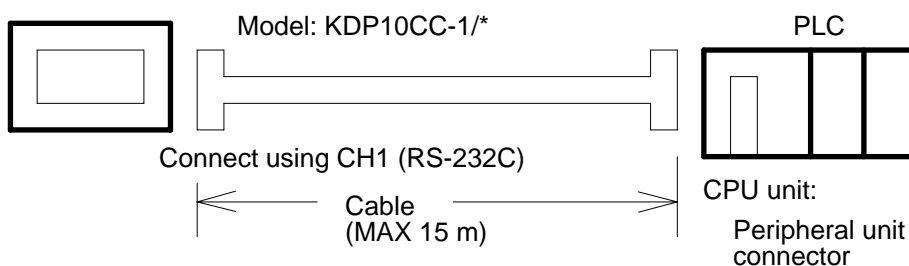

## 1.5 FX Series

The dedicated Mitsubishi cable (???/10CC-1/\*) can be used to perform 1:1 communications by connecting the OIP to the programming panel connector of the basic unit of the converter.

Select [Mistubishi (FX)] or [Mistubishi (FX 2 PORT)] from the connection devices of the “Project Property” on Screen Creator 5.

Select [Mistubishi (FX 2 PORT)] when a Mitsubishi 2-port adapter (FX-2PIF) is used.

In the case of using Mitsubishi (FX 2 PORT), the ROMs of the OIP (??? 300 series) must be of the following versions:

For connectable CPU types, refer to Section 2, “List of Connectable PLC Types” of Chapter II.

### 1) Notes for use



- Use CH1 as the OIP serial communication port. CH2 cannot be used.
- The number of devices from/in which data can be read/written at a time is as shown below.
- The number of devices from/in which data can be read/written at a time is as shown below.
 

Read:	128 ports (bit devices)/122 ports (word devices)
Write:	1 port (bit devices)/122 ports (word devices)
- Communication parameters
 

Set the communication parameters for OIP as shown below.

Those parameters are fixed in the CPU unit.

Communication rate:	9600 bps
Parity bit:	EVEN
Stop bit length:	1 bit
Data length:	7 bits

### 2) Usable station numbers and devices

Station number

00 (Set “00” for the station number, although no station number is assigned on the protocol.)

Devices



**This system does not support double-word counters (CN200 to CN255). When using double-word counters, arrangement should be made so that PLC transfers data to the data register and this system references to the data register.**

- Bit devices

Device name	Range
External input relay	X000 - X377
External output relay	Y000 - Y377
Auxiliary relay	M0000 - M1535
State	S000 - S999
Timer (contact)	TS000 - TS255
Counter (contact)	CS000 - CS255

- Word devices

Device name	Range
Data register	D000 - D999
Special data register	D8000 - D8999
Timer (current value)	TN000 - TN255
Counter (current value)	CN000 - CN199

### 3) OIP connection

For programming panel with D-sub 25-pin connector

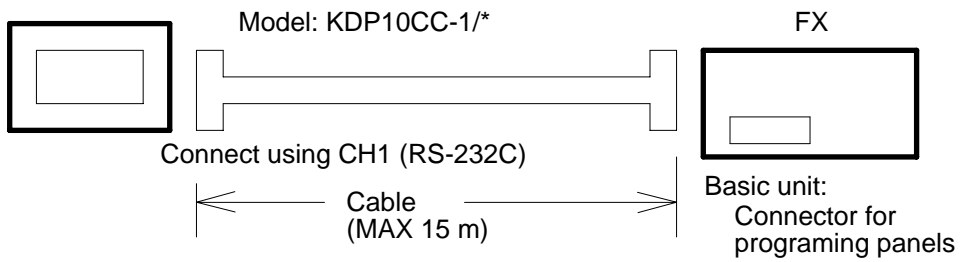

For programming panel with round connector

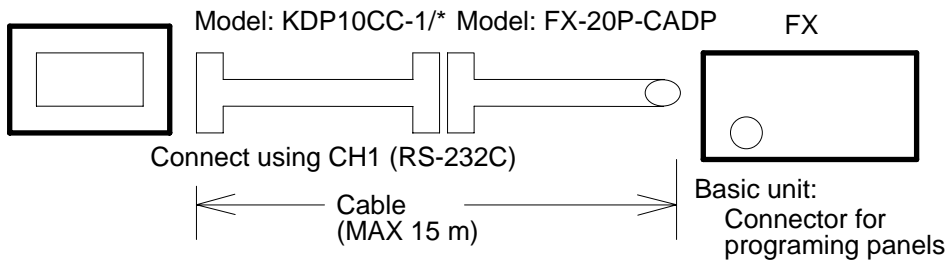

## 2. PLC Supplied by OMRON

### 2.1 SYSMAC C, CQM1, CPM1

Select [Omron (C)] or [Omron (C) (High-speed communication)] from the connection devices of the "Project Property" on Screen Creator 5.

"Omron (C) (High-speed communication)" provides high-speed communication, since it registers as many devices as possible in the PLC. Select "Omron (C)" when the multi-panel unit ???21NU-1 is used or M:N connection is performed.

#### 1) Setting a communication mode and notes for use



- Communication mode: Select the upper-link mode.
- Command level: Set level 3 to be valid. (Set only SYSMAC C.)
- Communication control protocol: The 1:N protocol is adopted. (Set only SYSMAC C.)
- When a bit device is selected, data will be written on a channel by channel basis, not bit by bit. The value "0" will therefore be set in all other bits of the same channel.  
Values written in bit devices are assured if cyclic communication is made using lamp displays and lamp switches arranged on the same screen. In other cases, use only one bit in the same channel.
- If some bits in a channel are used over screens, values written on another screen cannot be assured.
- Do not use bits as a coil in the same channel on the PLC side. It is recommended to use a different area on PLC and OIP respectively.
- The total number of devices on which data read/write operations can be carried out at a time is as follows:
 

Read/write:	128 ports (bit devices)
	28 ports (word devices)

#### 2) Usable station numbers and devices

Station numbers (PLC)

- 00 to 31 (Decimal notation)

OIP ID number in M:N connection

- 00 to 255 (Decimal notation)
- Set the OIP master ID number to 255.
- The OIP ID number must not be the same as the PLC ID number.

Devices

- Bit devices

Device name	Range
I/O relay, internal relay	00000 - 25515
Link relay	LR0000 - LR6315
Hold relay	HR0000 - HR9915



- Word devices

Device name	Range
Data register	DM0000 - DM9999
Timer (current value)	TM000 - TM511
Counter (current value)	NT000 - NT511
I/O relay, internal relay	0000 - 2555
Link relay	LR00 - LR63
Hold relay	HR00 - HR99

### 3) OIP connection

RS-232C (for DSUB-25P)

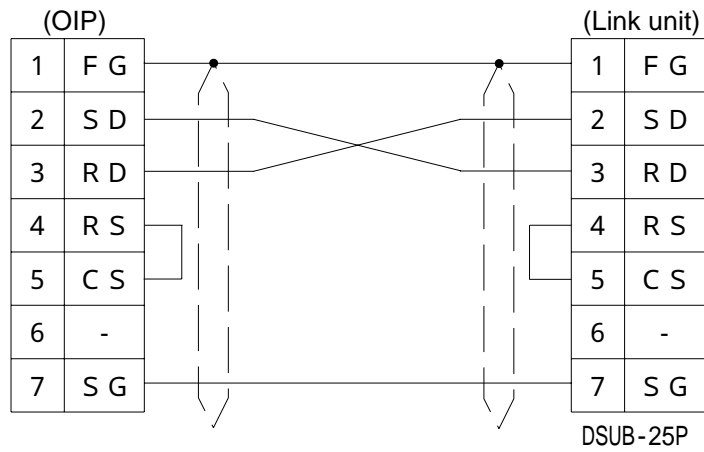

RS-232C (for DSUB-9P)

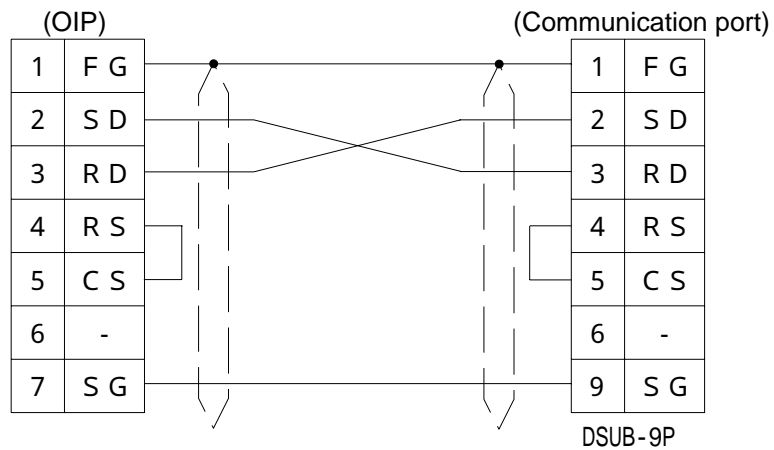

RS-485 [1:1, 1:N]

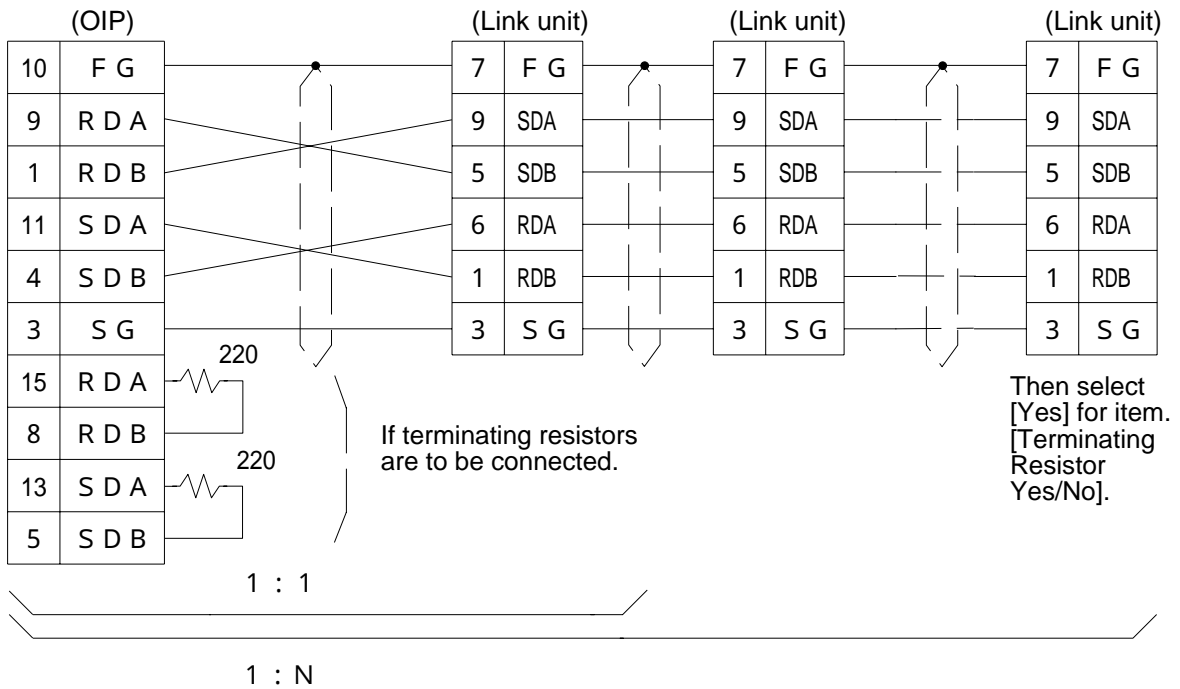

RS-485 [M:N]

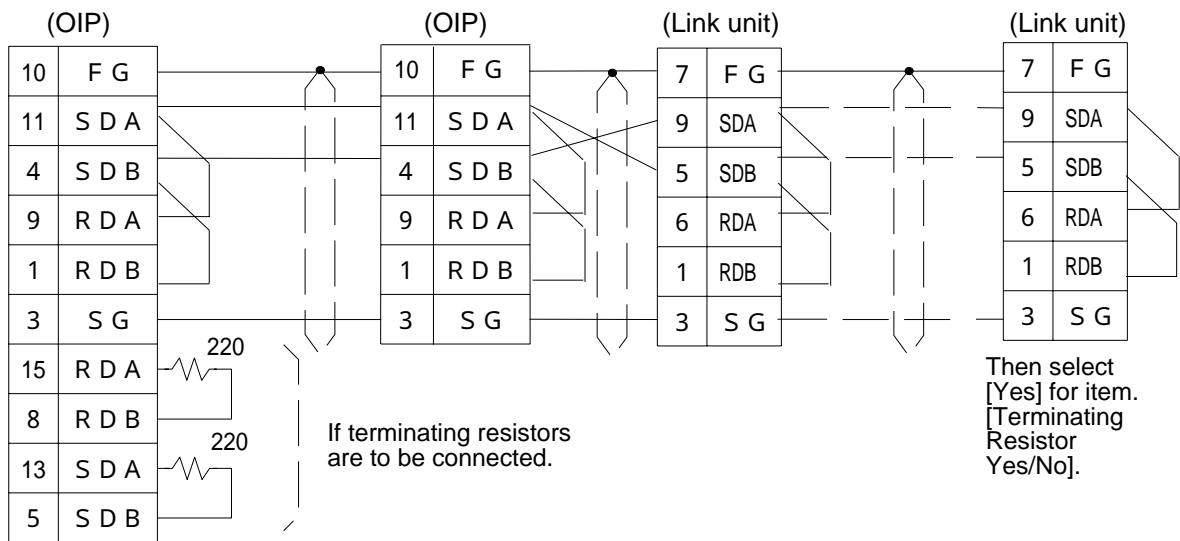

## 2.2 SYSMAC ( Series)

Select [Omron (SYSMAC )] from the connection devices of the “Project Property” on Screen Creator 5.

For connectable PLC types and link units, refer to Section 2, “List of Connectable PLC Types” of Chapter II.

### 1) Setting a link unit and notes for use



- Command mode: Set the upper link mode.
- The status is set in the monitor mode forcibly when a WRITE command is issued. The mode is not returned to the former one automatically. Thus, the monitor mode is kept as is after writing is executed even once.
- Writing is consecutively executed in bit devices in the same channel.
- The number of devices from/in which data can be read/written at a time is as shown below.

Read:	128 ports (bit devices)
	28 ports (word devices)
Write:	16 ports (bit devices) (limited in the same channel)
	28 ports (word devices)

### 2) Usable station numbers and devices

Station numbers (PLC)

- 00 to 31 (Decimal notation)

OIP ID number in M:N connection

- 00 to 255 (Decimal notation)
- Set the OIP master ID number to 255.
- The OIP ID number must not be the same as the PLC ID number.

Devices



**This system is designed so that devices that are not supported at present can also be declared to cope with the system expansion in the future. When any devices are to be used, check the device range of your PLC carefully.**

- Bit devices

Device name	Range
Input/output relay, internal relay	00000 - 99915
Link relay	LR0000 - LR9915
Hold relay	HR0000 - HR9915
Auxiliary memory relay	AR0000 - AR9915

- Word devices

Device name	Range
Data register	DM0000 - DM9999
Extended data memory	EM0000 - EM9999
Timer (current value)	TIM000 - TIM999
Counter (current value)	CNT000 - CNT999
Input/output relay, internal relay	000 - 999
Link relay	LR00 - LR99
Hold relay	HR00 - HR99
Auxiliary memory relay	AR00 - AR99

How to specify bank in extended data memory

To specify a bank, use “.” in selecting a device.

Example: In case of Station no.: 00, Bank specification: 2, Device name: EM100,  
00-2. EM100

When the bank specification is not described, “current bank” is automatically set.

### 3) OIP connection

These connections are made in the same way as that stated in subsection 2-1, “SYSMAC C, CQM1, CPM1”, (see pages II 2-2 and II 2-3).

## 2.3 SYSMAC (CV Series)

Select [Omron (C)] from the connection devices of the “Project Property” on Screen Creator 5. For the connectable PLC types and link units, refer to Section 2, “List of Connectable PLC Types” of Chapter II

### 1) Notes for use



- Command architecture
- When a bit device is selected, data will be written on a channel by channel basis, not bit by bit. The value “0” will therefore be set in all other bits of the same channel.  
Values written in bit devices are assured if cyclic communication is made using lamp displays and lamp switches arranged on the same screen. In other cases, use only one bit in the same channel.
- If some bits in a channel are used over screens, values written on another screen cannot be assured.
- Do not use bits as a coil in the same channel on the PLC side. It is recommended to use a different area on PLC and OIP respectively.
- The total number of devices on which data read/write operations can be carried out at a time is as follows:
  - Read/write: 128 ports (bit devices)
  - 32 ports (word devices)

### 2) Usable station numbers and devices

#### Station number

- 00 to 31 (Decimal notation)

#### OIP ID number in M:N connection

- 00 to 255 (Decimal notation)
- Set the OIP master ID number to 255.
- The OIP ID number must not be the same as the PLC ID number.

#### Devices

- Bit devices

Device name	Range
CIO area	000000 - 255515
CPU bus link relay	G00000 - G25515
Special auxiliary relay	A00000 - A51115
Timer increment flag	TF0000 - TF1023
Counter flag	CF0000 - CF1023

- Word devices

Device name	Range
Data memory	D00000 - D24575
Extended data memory	E00000 - E32765
Timer (current value)	T0000 - T1023
Counter (current value)	C0000 - C1023
CIO area	0000 - 2555
CPU bus link relay	G000 - G255
Special auxiliary relay	A000 - A511

(Bank 0 only)

### 3) OIP connection

RS-232C (for connection to the link I/F of CPU unit)

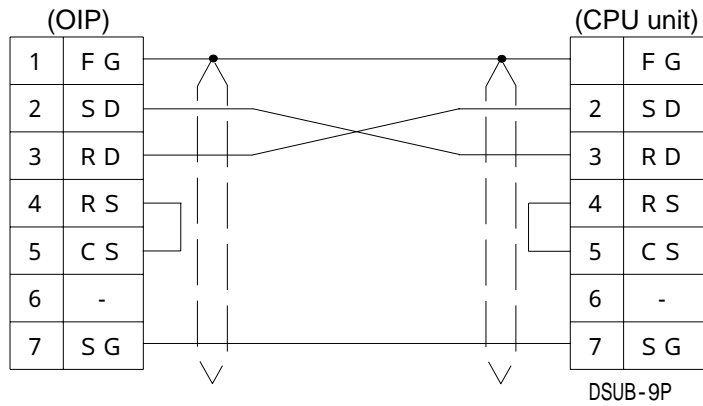

RS-485 (for connection to the link I/F of CPU unit) [1:1, 1:N]

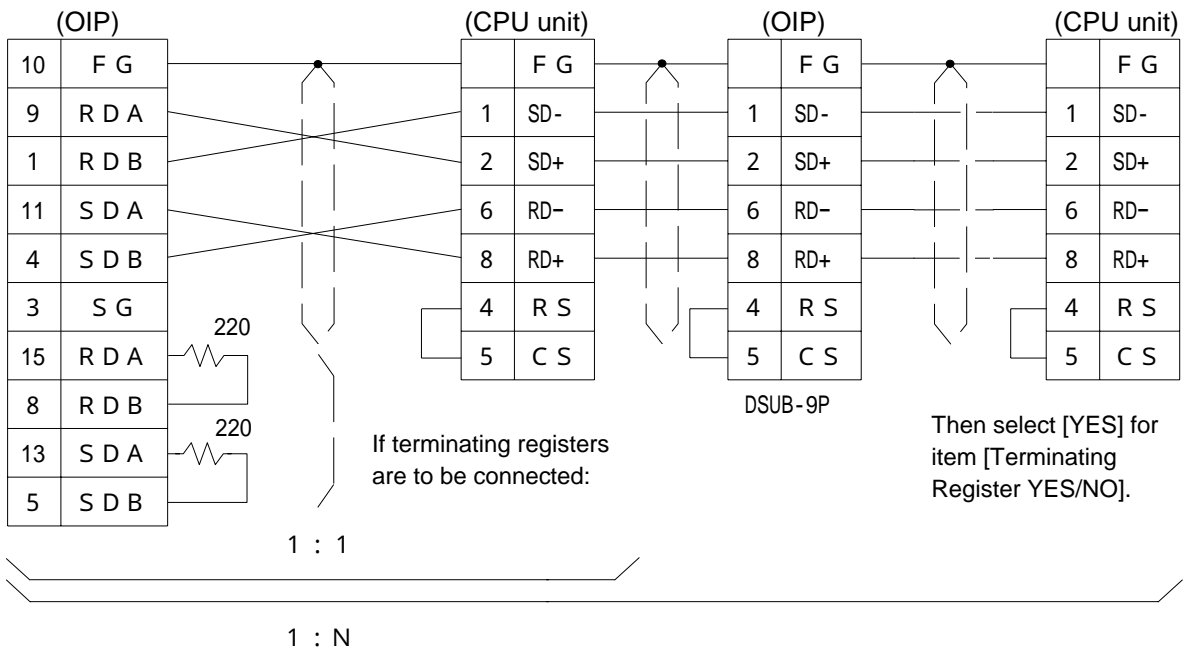

RS-485 (for connection to the link I/F of CPU unit) [M:N]

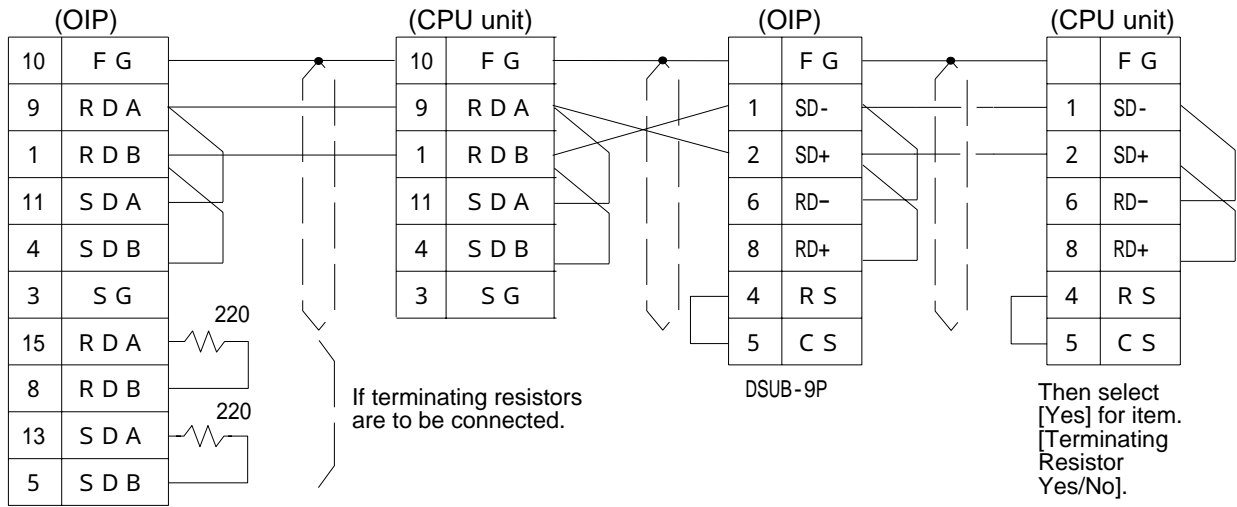

## 3. PLC Supplied by Fuji

### 3.1 FLEX-PC (NJ, NS or NB Series)

Select [Fuji (NJ/NS)] from the connection devices of the “Project Property” on Screen Creator 5. For connectable PLC types and link units, refer to Section 2, “List of Connectable PLC Types” of Chapter II.

#### 1) Setting a link unit and notes for use



- Communication procedure: Select non procedure asynchronous communication of the command-setting type.
- The total number of devices on which data read/write operations can be carried out at a time is as follows:
 

Read:	128 ports (bit devices)
	32 ports (word devices)
Write:	1 port (bit devices)
	32 ports (word devices)

- Initial settings

	Item	Setting	Value
1	Transmission procedure	None	0
2	Mode	SET	1
3	Receive message No.	0 (fixed)	0
4	Baud rate	9600	5
5	Data length	8	1
6	Parity bit	Even	2
7	Stop bits	1	0
8	DCE/DTE mode	DCE mode	0
9	CTS/RTS control	Continually on	1
10	DSR/DTR control	Continually on	0
11	Transmission conditions	None	2
12	–		

	Item	Setting	Value
13	Transmission code	JIS	0
14	Code conversion	Yes	1
15	Receive data bytes	0	0
16	Start code:	2	
17	End code	CR·LF	4
18	Start code 1, 2	–	0
19	End code 1, 2	–	0
20	BCC	SET 1	1
21	Position (area)	TEXT	0
22	Calculation expression	Addition	0
23	Code	Transmission code	0
24	Timer	25.5 sec	OFFH

- Notes: 1. The above hatched setting and set values can be selected according to the communication parameters of the OIP. Other settings and set values cannot be modified once they are set.
2. For initial setting as listed in the table above, first create a file and then set initial data in this file using a loader. Next, an instruction for transferring the data to the link unit is to be incorporated into the ladder program.



- **Writing is not executed in bit devices one by one. Data is always written word by word. So, “0” is written in all the bits in the same word except in the object one. Values written in bit devices are assured if cyclic communication is made using lamp displays and lamp switches arranged on the same screen. In other cases, use only one bit in the same channel.**
- **If some bits in a channel are used over screens, values written on another screen cannot be assured.**
- **Do not use bits as a coil in the same channel on the PLC side. It is recommended to use a different area on PLC and OIP respectively.**



## 2) Usable station numbers and devices

### Station numbers

- 00 to 99 (Decimal notation)

### OIP ID number in M:N connection

- 00 to 255 (Decimal notation)
- Set the OIP master ID number to 255.
- The OIP ID number must not be the same as the PLC ID number.

### Devices

- Bit devices

Device name	Range
Input relay	X0000 - X03FF
Output relay	Y0000 - Y03FF
Internal relay	M0000 - M03FF
Latch relay	L0000 - L03FF
Timer (contact)	TC0000 - TC01FF
Counter (contact)	CC0000 - CC00FF

- Word devices

Device name	Range
Data register	D0000 - D06FF
File register	R0000 - R3DFF
Timer (current value)	TN0000 - TN01FF
Counter (current value)	CN0000 - CN00FF

## 3) OIP connection

RS-232C (for NJ-RS2)

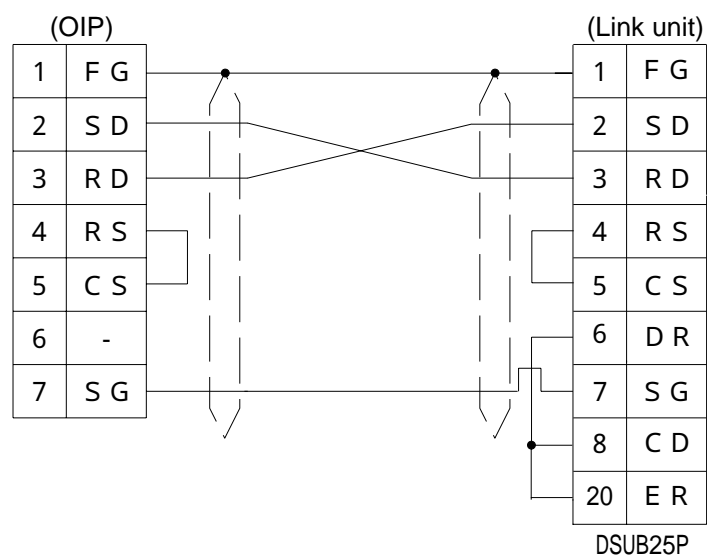

RS-422/RS-485 (for NJ-RS4) [1:1, 1:N]

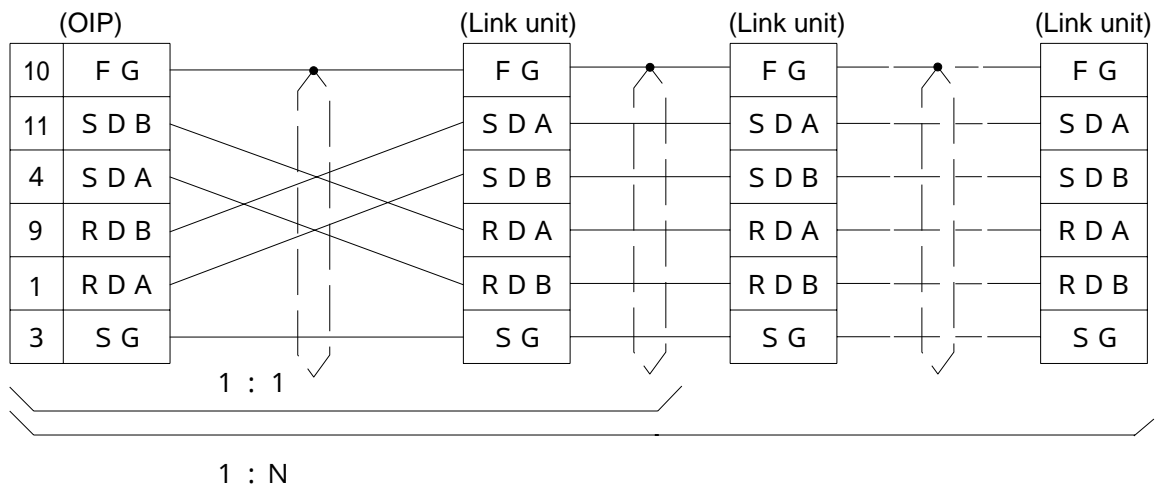

RS-485 (for NJ-RS4) [M:N]

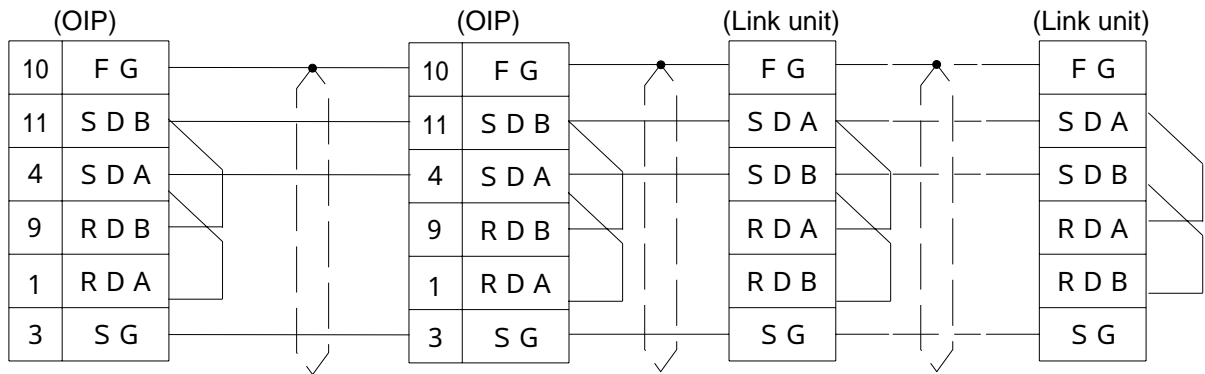

## 3.2 FLEX-PC (NJ-T, NS-T Series)

Select [Fuji (NJ-T/NS-T)] from the connection devices of "Project Property" on Screen Creator 5. For connectable PLC types and link units, refer to Section 2, "List of Connectable PLC Types" of Chapter II.

### 1) Setting a link unit and notes for use



- Communication procedure: Select non procedure asynchronous communication of the command-setting type.
- The total number of devices on which data read/write operations can be carried out at a time is as follows:
 

Read:	128 ports (bit devices)
	64 ports (word devices)
Write:	1 port (bit devices)
	64 ports (word devices)

- Initial settings

	Item	Setting	Value
1	Transmission procedure	None	0
2	Mode	SET	1
3	Receive message No.	0 (fixed)	0
4	Baud rate	9600	5
5	Data length	8	1
6	Parity bit	Even	2
7	Stop bits	1	0
8	DCE/DTE mode	DCE mode	0
9	CTS/RTS control	Continually on	1
10	DSR/DTR control	Continually on	0
11	Transmission conditions	None	2
12	–		

	Item	Setting	Value
13	Transmission code	JIS	0
14	Code conversion	Yes	1
15	Receive data bytes	0	0
16	Start code	:	2
17	End code	CR·LF	4
18	Start code 1, 2	–	0
19	End code 1, 2	–	0
20	BCC	SET 1	1
21	Position (area)	TEXT	0
22	Calculation expression	Addition	0
23	Code	Transmission code	0
24	Timer	25.5 sec	0FFH

- Notes: 1. The above hatched setting and set values can be selected according to the communication parameters of the OIP. Other settings and set values cannot be modified once they are set.
2. For initial setting as listed in the table above, first create a file and then set initial data in this file using a loader. Next, an instruction for transferring the data to the link unit is to be incorporated into the ladder program.

## 2) Usable station numbers and devices

### Station numbers

- 00 to 99 (Decimal notation)

### Devices

- Bit devices

Devicename	Range
Input relay	X0000 - X07FF
Output relay	Y0000 - Y07FF
Internal relay	M0000 - M03FF
Extended internal relay	M0400 - M1FFF
Keep relay	K0000 - K03FF
Extended keep relay	K0400 - K1FFF
Special relay	V0000 - V01FF
Timer (contact)	TC0000 - TC03FF
Counter (contact)	CC0000 - CC01FF

- Word devices

Device name	Range
Data register	D0000 - D2FFF
File register	W0000 - W7FFF
Link register	R0000 - R3FFF
Timer (current value)	TN0000 - TN03FF
Counter (current value)	CN0000 - CN01FF
Special register	Z0000 - Z037F
Input relay	X0000W - X007FW
Output relay	Y0000W - Y007FW
Internal relay	M0000W - M003FW
Extended internal relay	M0040W - M01FFW
Keep relay	K0000W - K003FW
Extended keep relay	K0040W - K01FFW
Special relay	V0000W - V001FW
Timer (contact)	TC0000W - TC003FW
Counter (contact)	CC0000W - CC001FW

### 3) OIP connection

RS-232C [NJ-RS1, NJ-RS2]

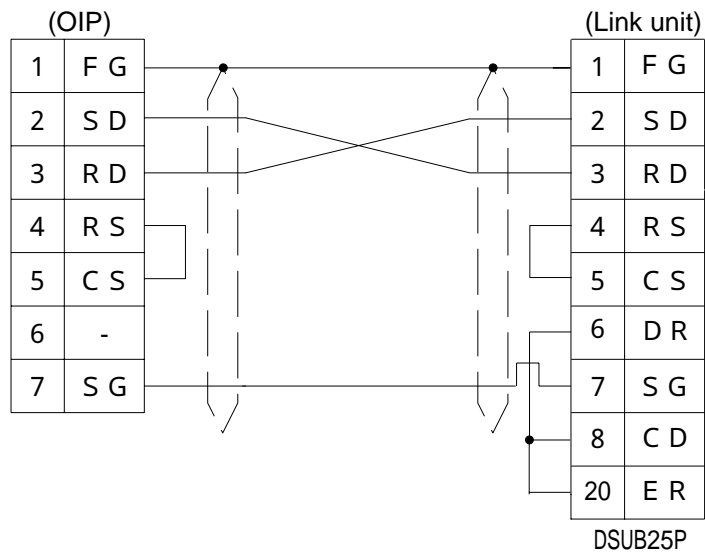

RS-485 [NJ-RS1, NJ-RS4] [1:1, 1:N]

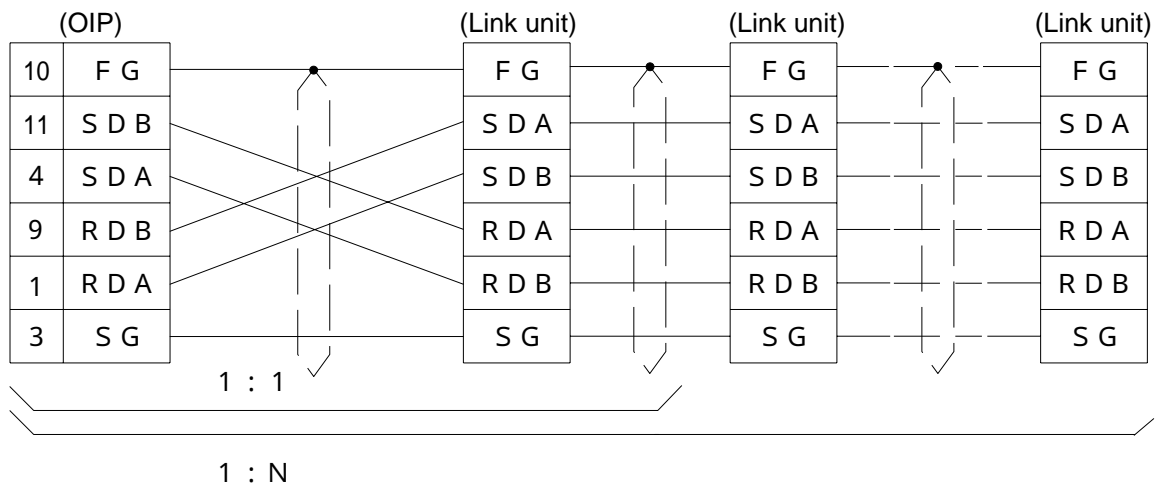

### 3.3 FLEX-PC (Computer link)

Select [Fuji (computer link)] from the connection devices of “Project Property” on Screen Creator 5. For connectable PLC types and link units, refer to Section 2, “List of Connectable PLC Types” of Chapter II.

#### 1) Setting a link unit and notes for use



- Communication procedure: Use transmission format for computer links.
- The total number of devices on which data read/write operations can be carried out at a time is as follows:
 

Read:	128 ports (bit devices)
	64 ports (word devices)
Write:	1 port (bit devices)
	64 ports (words other than current values of Timer or Counter)
	1 port (current values of Timer or Counter)

#### 2) Usable station numbers and devices

Station numbers

- 00 to 37 (Octal notation)

Devices

- Bit devices

Devicename	Range
Input relay	X0000 - X07FF
Output relay	Y0000 - Y07FF
Internal relay	M0000 - M03FF
Extended internal relay	M0400 - M1FFF
Keep relay	K0000 - K03FF
Extended keep relay	K0400 - K1FFF
Special relay	V0000 - V01FF
Timer (contact)	TC0000 - TC03FF
Counter (contact)	CC0000 - CC01FF

- Word devices

Device name	Range
Data register	D0000 - D2FFF
File register	W0000 - W7FFF
Link register	R0000 - R3FFF
Timer (current value)	TN0000 - TN03FF
Counter (current value)	CN0000 - CN01FF
Special register	Z0000 - Z037F
Input relay	X0000W - X007FW
Output relay	Y0000W - Y007FW
Internal relay	M0000W - M003FW
Extended internal relay	M0040W - M01FFW
Keep relay	K0000W - K003FW
Extended keep relay	K0040W - K01FFW
Special relay	V0000W - V001FW
Timer (contact)	TC0000W - TC003FW
Counter (contact)	CC0000W - CC001FW

### 3) OIP connection

RS-485 (4-wire) [1:1, 1:N]

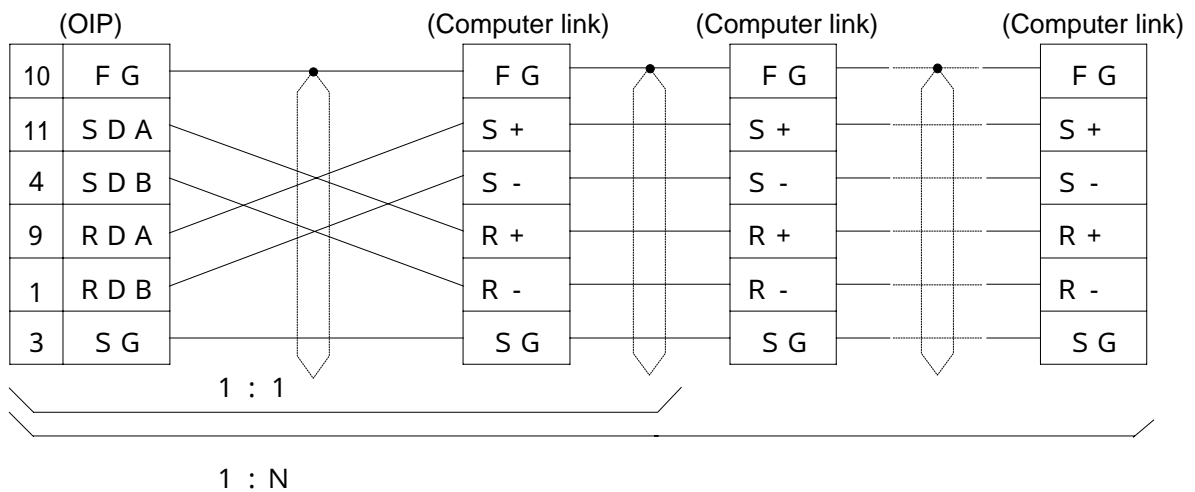

RS-485 (2-wire) [1:1, 1:N]

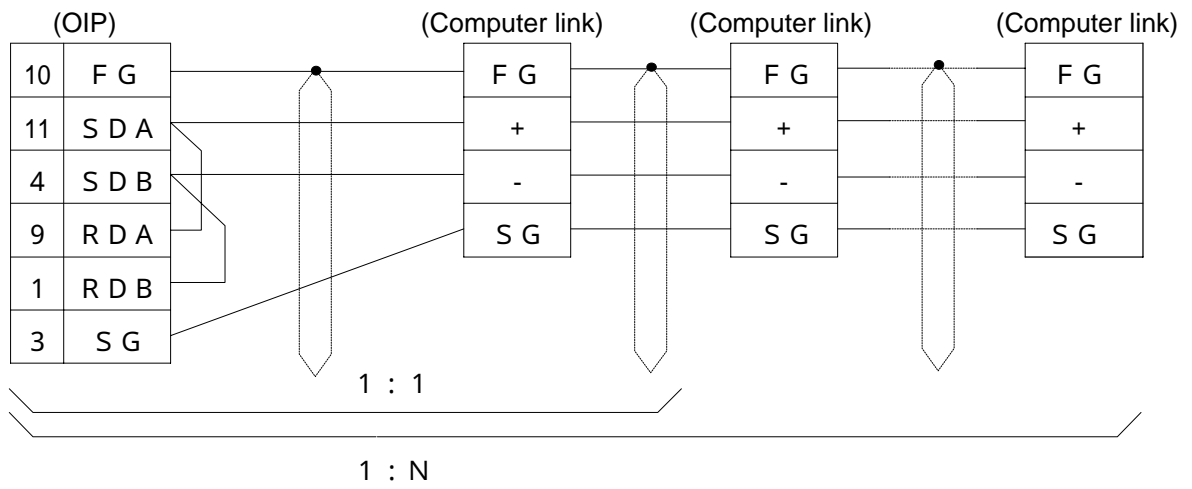



### 3.4 FLEX-PC (Loader command)

Select [Fuji (loader command)] from the connection devices of "Project Property" on Screen Creator 5. For connectable PLC types and link units, refer to Section 2, "List of Connectable Types" of Chapter II.

#### 1) Setting a link unit and notes for use



- Communication procedure: Use loader command.
- The total number of devices on which data read/write operations can be carried out at a time is as follows:
 

Read:	128 ports (bit devices)
	64 ports (word devices)
Write:	1 port (bit devices)
	64 ports (word devices)
- Communication parameter: Set the communication parameters of the OIP as shown below. They are fixed in the CPU unit.
 

Communication rate:	19200 bps
Parity:	ODD
Stop bit:	1 bit
Data length:	8 bits

#### 2) Usable station numbers and devices

##### Station numbers

- 00 (The protocol is not numbered with station number but specified with 00.)

##### Devices

- Bit devices

Devicename	Range
Input relay	X0000 - X07FF
Output relay	Y0000 - Y07FF
Internal relay	M0000 - M03FF
Extended internal relay	M0400 - M1FFF
Keep relay	K0000 - K03FF
Extended keep relay	K0400 - K1FFF
Special relay	V0000 - V01FF
Timer (contact)	TC0000 - TC03FF
Counter (contact)	CC0000 - CC01FF

- Word devices

Device name	Range
Data register	D0000 - D2FFF
File register	W0000 - W7FFF
Link register	R0000 - R3FFF
Timer (current value)	TN0000 - TN03FF
Counter (current value)	CN0000 - CN01FF
Special register	Z0000 - Z037F
Input relay	X0000W - X007FW
Output relay	Y0000W - Y007FW
Internal relay	M0000W - M003FW
Extended internal relay	M0040W - M01FFW
Keep relay	K0000W - K003FW
Extended keep relay	K0040W - K01FFW
Special relay	V0000W - V001FW
Timer (contact)	TC0000W - TC003FW
Counter (contact)	CC0000W - CC001FW

### 3) OIP connection

RS-485 (in the case that DSUB-15P is used as a peripheral unit)

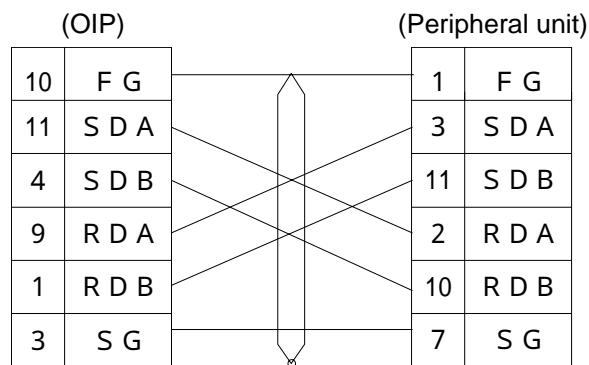

### 3.5 MICREX-F Series

Select "Fuji (MICREX-F)" from the connection devices registered on the "Project Property" on Screen Creator 5.

For connectable PLC types and link units, refer to 2, "List of Connectable PLC Types" of Chapter II.

#### 1) Usable station numbers and devices

##### Station numbers

- 00 to 99 (Decimal notation)

##### OIP ID number in M:N connection

- 00 to 255 (Decimal notation)
- Set the OIP master ID number to 255.
- The OIP ID number must not be the same as the PLC ID number.

##### Devices

- Bit devices



**This system is designed so that devices that are not supported at present can also be declared to cope with the system expansion in the future. When any devices are to be used, check the device range of your PLC carefully.**

- Bit devices

Device name	Range
Input/output relay	B0000 - B999F
Auxiliary relay	M0000 - M999F
Keep relay	K0000 - K999F
Differential relay	D0000 - D999F
Special relay	F0000 - F999F
Announce relay	A0000 - A999F

- Word devices

Device name	Range
Input/output relay	WB0000 - WB0999
Direct access	W24.0000 - W24.9999
Timer (set value)	TS0000 - TS9999
Timer (current value)	TR0000 - TR9999
Counter (set value)	CS0000 - CS9999
Counter (current value)	CR0000 - CR9999
Data memory	BD0000 - BD9999
User file (16 bits)	W30.0000 - W30.9999
User file (16 bits)	W31.0000 - W31.9999
User file (16 bits)	W32.0000 - W32.9999
User file (32 bits)	W33.0000 - W33.9999
User file (32 bits)	W34.0000 - W34.9999

## 2) Setting communication functions and notes for use

- The number of devices from/in which data can be read/written at a time is as shown below.

Read/write: 128 ports (bit devices)  
 32 ports (16-bit devices)  
 29 ports (32-bit devices)

- Initial setting

	Item	Setting	Value
1	Transmission procedure	None	0
2	Mode	SET	1
3	Receive message No.	0 (fixed)	0
4	Baud rate	9600	5
5	Data length	8	1
6	Parity bit	Even	2
7	Stop bits	1	0
8	DCE/DTE mode	DCE mode	0
9	CTS/RTS control	Continually on	1
10	DSR/DTR control	Continually on	0
11	Transmission conditions	None	2
12	–		

	Item	Setting	Value
13	Transmission code	JIS	0
14	Code conversion	Yes	1
15	Receive data bytes	0	0
16	Start code	:	2
17	End code	CR·LF	4
18	Start code 1, 2	–	0
19	End code 1, 2	–	0
20	BCC	None	1
21	Position (area)	–	0
22	Calculation expression	–	0
23	Code	Transmission code	0
24	Timer	25.5 sec	0FFH

- Notes: 1. The hatched items in the above table can be selected according to the particular settings of the communication parameters of the OIP. For all other items, do not modify settings once data has been set.
2. For initial setting as listed in the table above, first create a file and then set initial data in this file using a loader. Next, an instruction for transferring the data to the link unit is to be incorporated into the ladder program.  
 (For details, refer to the link unit manual.)

- Set the user file area as shown below in the user definition.

16-bit data: W30.0000 - W30.9999  
 W31.0000 - W31.9999  
 W32.0000 - W32.9999  
 32-bit data: W33.0000 - W33.9999  
 W34.0000 - W34.9999

- In the Fuji Denki's specifications, the MSB of word devices corresponds to bit 0 of bit devices and the LSB corresponds to bit F.  
 Example: In address WB0002, a value is written in bit devices as shown below.  
 If "0001" (hexadecimal) is written in an address "WB0002", 1 is set in the B002F bit device as shown below.

B002

	0	1	2	3	4	5	6	7	8	9	A	B	C	D	E	F	
WB0002	0	0	0	0	0	0	0	0	0	0	0	0	0	0	0	1	If "0001" (hexadecimal) is written

- In OIP, basically, data is processed assuming one word as 16 bits. Thus, 32-bit data processings are limited as shown below.

[When described in a screen/part program]

Writing

Data is written in the lower 16 bits of the 32 bits and "0" is written in the upper 16 bits.

**Reading of an event**

Of the 32-bit data, the data in the lower 16 bits is read.

**Cyclic reading**

All the 32 bits are read.

If 32-bit data is declared as consecutive cyclic data, the GETID and GETOFFSET commands take offset values double the normal ones when they are executed.

Example: Modify the GETID and GETOFFSET programs in the manual (program description) as shown below to make them correspond to 32-bit data.

```
CONF
CYCLIC 00-BD0000 * 30
END CONF
EVNT
INPUT  TY%, ID@, DAT%
OFFSET = GETOFFSET (00-BD0000, ID@)/2
...
An error processing, etc. corresponding to the offset value
...
ID@ = GETID (00-BD0000, OFFSET*2)
...
END EVNT
```

[When validating control operation parameters]

**Switch/selector switch**

Of 32-bit data, data in only the lower 16 bits can be used.

If "ON" is set for "synchronous operation", do not change the data in the upper 16 bits on the PLC side.

**Character/graphic display**

For a 32-bit device, set "1" for "number of consecutive devices". If another value is set, the device will malfunction.

**Bar/kinked line graph**

Of 32-bit data, data in only the lower 16 bits can be used for sampling processing. For a kinked line graph, set "1" for "number of lines". If another value is set, the device will malfunction.

If no sampling processing is to be executed, no 32-bit device can be used for kinked line graphs. For a bar graph, set "1" for "number of bars". If another value is set, the device will malfunction.

**Plot/belt/circle graph**

No 32-bit device can be used.



- **Writing is not executed in bit devices one by one. Data is always written word by word. So, "0" is written in all the bits in the same word except in the object one. Values written in bit devices are assured if cyclic communication is made using lamp displays and lamp switches arranged on the same screen. In other cases, use only one bit in the same channel.**
- **If some bits in a channel are used over screens, values written on another screen cannot be assured.**
- **Do not use bits as a coil in the same channel on the PLC side. It is recommended to use a different area on PLC and OIP respectively.**

### 3) OIP connection

RS-232C

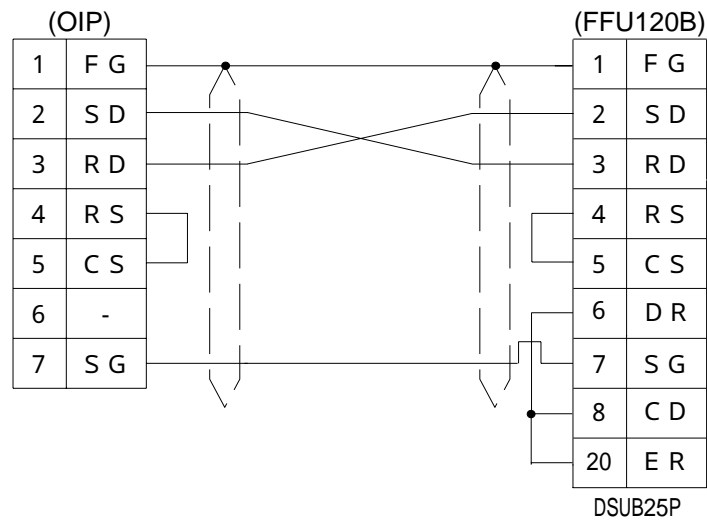

RS-485 [1:1, 1:N]

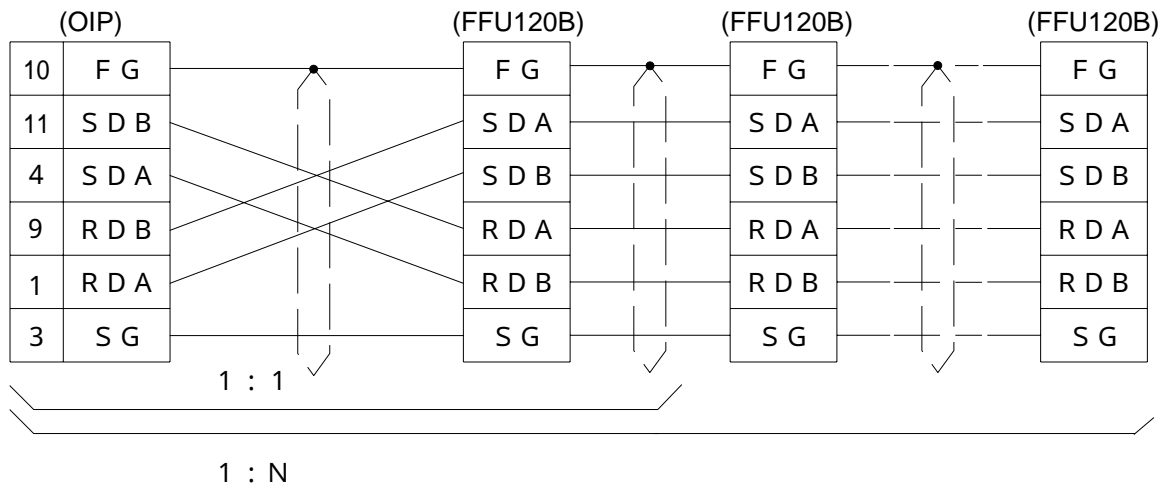

RS-485 [M:N]

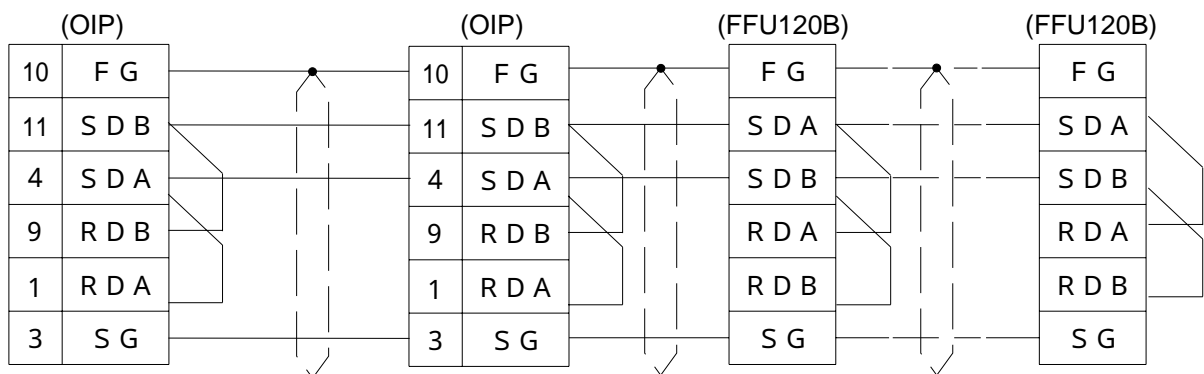

T link

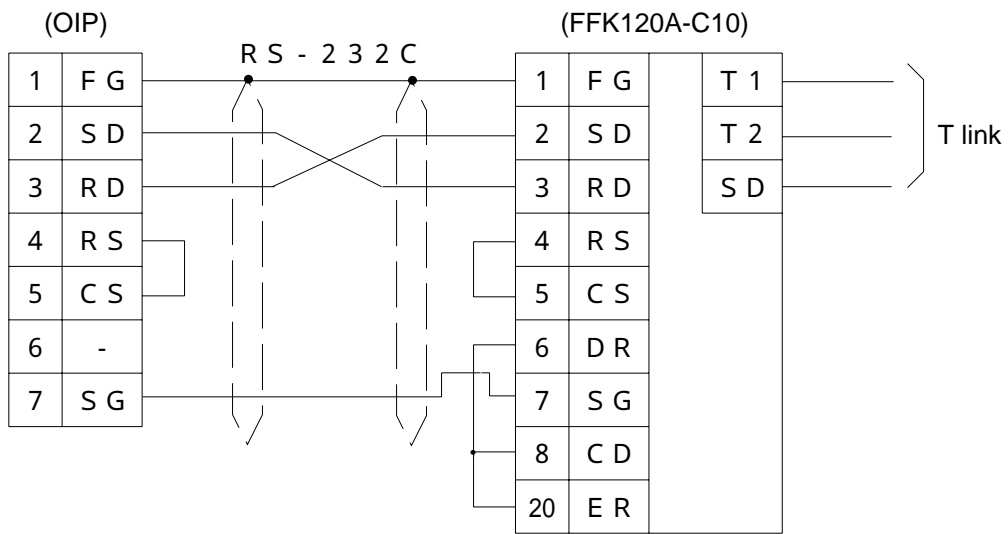

## 4. PLC Supplied by Hitachi

### 4.1 H-Series (with station number assignment)

Select [Hitachi (H) (LINK)] or [Hitachi (H) (LINK) (Non-occupation)] from the connection devices of the "Project Property" on Screen Creator 5.

For connectable PLC types and link units, refer to Section 2, "List of Connectable PLC Types" of Chapter II.



Refer to the section 4.2, "H-Series without station number assignment" or section 4.4, "H-Series without station number assignment" if the peripherals connector of a CPU module or a remote I/O module is to be used for connection.

Also refer to the same section if "no station No". is set for the COMM module.



The Hitachi (H) (Direct connection to CPU) (Non-occupation) does not occupy the memory used for read or write operation to PLC devices. Therefore applicable H series models are limited. For connectable PLC types, refer to Section 2, "List of Connectable PLC Types" of Chapter II.

The Hitachi (H) (Direct connection to CPU) automatically executes the command of "memory occupation or occupation reset" in making a write operation.

#### 1) Setting a link unit and notes for use



- Operation mode: Select transmission control procedure 1 of a data link level, one-way starting, and station number assignment.
- Sum check: Always select [Yes].
- Network addresses
 

L (loop number)	= FF(H) [fixed]
U (unit number)	= FF(H) [fixed]
M (module number)	= 00(H) [fixed]
P (port number)	= 00(H) [fixed]
- The total number of devices on which data read/write operations can be carried out at a time is as follows:
 

Read:	128 ports (bit devices)
	29 ports (word devices)
Write:	128 ports (bit devices)
	19 ports (word devices)



## 2) Usable station numbers and devices

## Station numbers

- 00 to 31 (Decimal notation)

## Devices

- Bit devices

Device name	Range
Internal output relay	R000 - R7FF
CPU link area 1	L0000 - L3FFF
CPU link area 2	L10000 - L13FFF
Data area	M0000 - M3FFF
External input relay	X0usb
External output relay	Y0usb
Remote external input relay	Xrtsb
Remote external output relay	Yrtsb

\*u: Unit No. (0H-9H)  
s: Slot No. (0H-AH)  
b: Internal module bit No. (00-95)  
\*r: Remote master sta. No. (1H-4H)  
t: Remote slave sta. No. (0H-9H)  
s: Slot No. (0H-9H)  
b: Internal module bit No. (00-95)

- Word devices

Device name	Range
CPU link area 1	WL000 - WL3FF
CPU link area 2	WL1000 - WL13FF
Internal output relay	WR0000 - WRC3FF
Special internal output relay	WRF000 - WRF1FF
Data area	WM000 - WM3FF
External input relay	WX0usm
External output relay	WY0usm
Remote external input relay	WXrtsm
Remote external output relay	WYrtsm
Timer/counter (current value)	TC000 - TC511

\*u: Unit No. (0H-9H)  
s: Slot No. (0H-AH)  
m: Internal module word No. (0-7)  
\*r: Remote master sta. No. (1H-4H)  
t: Remote slave sta. No. (0H-9H)  
s: Slot No. (0H-9H)  
m: Internal module word No. (0-7)

### 3) OIP connection

RS-232C

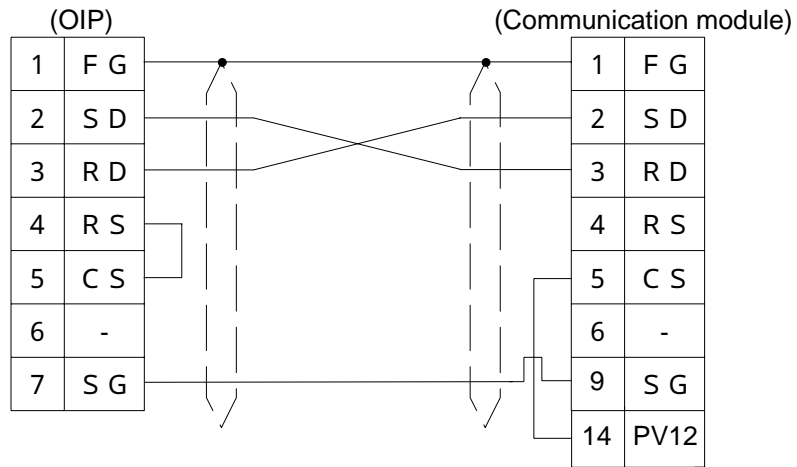

RS-232C [1:1, 1:N]

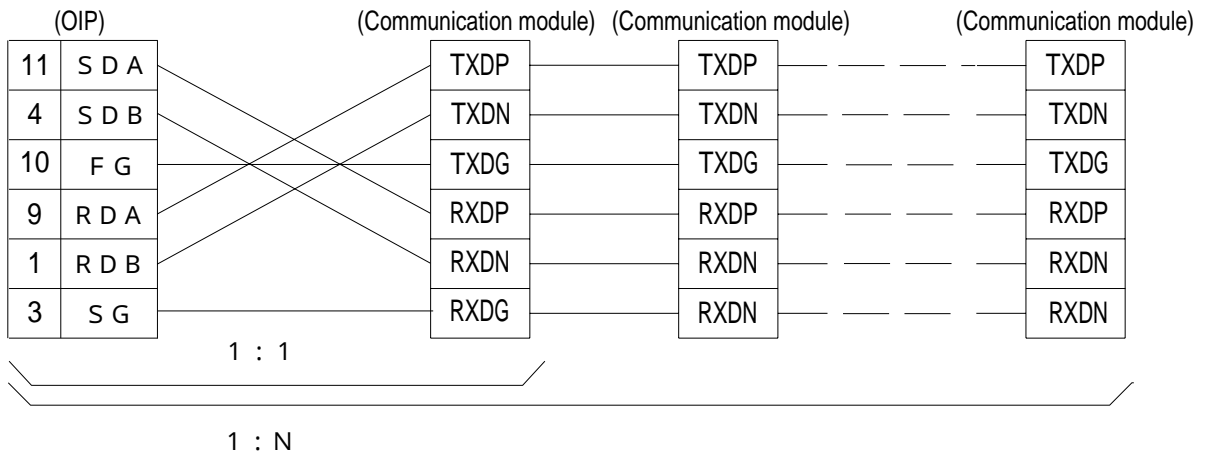

## 4.2 H-Series (without station number assignment)

Connection of the peripherals connector of a CPU module or a remote I/O module allows 1:1 communication without using a COMM module.

Select [Hitachi (H) (Direct connection to CPU)] or [Hitachi (H) (Direct connection to CPU) (Non-occupation)] from the connection devices of the "Project Property" on Screen Creator 5.

For connectable PLC types and link units, refer to Section 2, "List of Connectable PLC Types" of Chapter II.



Select [No station number assignment] if a COMM module is to be used.



The Hitachi (H) (Direct connection to CPU) (Non-occupation) does not occupy the memory used for read or write operation to PLC devices. Therefore applicable H series models are limited. For connectable PLC types, refer to Section 2, "List of Connectable PLC Types" of Chapter II.

The Hitachi (H) (Direct connection to CPU) automatically executes the command of "memory occupation or occupation reset" in making a write operation.

### 1) Setting a link unit and notes for use



- Destination of connection: Select the peripherals (special communication procedure) port of a CPU unit or remote I/O module.  
If the OIP is to be connected to a COMM module, set the communication parameters of the OIP to those of the module.
- Operation mode: Select transmission control procedure 1 of a data link level, one-way starting, and station number assignment.
- Check sum: Set 'Yes'.
- Communication parameters: If the OIP is to be connected to a CPU unit or a remote I/O module, set the communication parameters of the OIP as follows:
 

Baud rate:	4800/19200 bps (select either using a PHL signal)
Parity:	Even
Stop bits:	1
Data length:	7 bits
- Network addresses
 

L (loop number)	= FF(H) [fixed]
U (unit number)	= FF(H) [fixed]
M (module number)	= 00(H) [fixed]
P (port number)	= 00(H) [fixed]
- The total number of devices on which data read/write operations can be carried out at a time is as follows:
 

Read:	128 ports (bit devices) 29 ports (word devices)
Write:	128 ports (bit devices) 19 ports (word devices)

## 2) Usable station numbers and devices

### Station numbers

- 00 (although no station number is required for the protocol, specify "00" here.)

### Devices

- Bit devices

Device name	Range
Internal output relay	R000 - R7FF
CPU link area 1	L0000 - L3FFF
CPU link area 2	L10000 - L13FFF
Data area	M0000 - M3FFF
External input relay	X0usb
External output relay	Y0usb
Remote external input relay	Xrtsb
Remote external output relay	Yrtsb

\*u: Unit No. (0H-9H)  
s: Slot No. (0H-AH)  
b: Internal module bit No. (00-95)  
\*r: Remote master sta. No. (1H-4H)  
t: Remote slave sta. No. (0H-9H)  
s: Slot No. (0H-9H)  
b: Internal module bit No. (00-95)

- Word devices

Device name	Range
CPU link area 1	WL000 - WL3FF
CPU link area 2	WL1000 - WL13FF
Internal output relay	WR0000 - WRC3FF
Special internal output relay	WRF000 - WRF1FF
Data area	WM000 - WM3FF
External input relay	WX0usm
External output relay	WY0usm
Remote external input relay	WXrtsm
Remote external output relay	WYrtsm
Timer/counter (current value)	TC000 - TC511

\*u: Unit No. (0H-9H)  
s: Slot No. (0H-AH)  
m: Internal module word No. (0-7)  
\*r: Remote master sta. No. (1H-4H)  
t: Remote slave sta. No. (0H-9H)  
s: Slot No. (0H-9H)  
m: Internal module word No. (0-7)

### 3) OIP connection

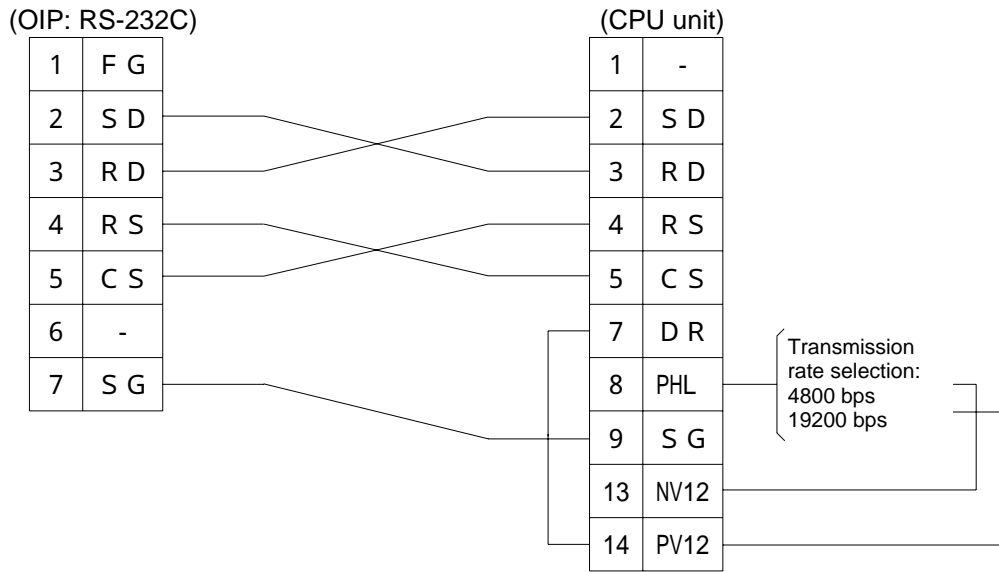

- Connect the CPU unit to an RS-232C (CH1) port of the OIP.
- If, as shown in 4.1), the RS or CS signal line is not to be used, then some specific models (such as the H-200) of the CPU unit may not correctly operate.

## 5. PLC Supplied by Sharp

### 5.1 New Satellite JW Series (for link unit)

Select [Sharp (Link)] from the connection devices of the “Project Property” on Screen Creator 5. For connectable PLC types and link units, refer to Section 2, “List of Connectable PLC Types” of Chapter II.



**If the OIP is connected to a communication port of JW20/JW70CU/JW100CU, refer to 5.2, “JW (for communication port)”.**

#### 1) Setting a link unit and notes for use



- Communication function: Select the command mode of the computer link function.  
(Parameters are fixed as follows: Data length = 7, Parity = Yes, Stop bits = 2)
- The system memory (#), TIM-CNT current value, MD information (W) can be read, but not written.
- When a write command is issued, Write Mode 1 will be forcibly set. Since the original mode will not be subsequently reset, Write Mode 1 will remain set once a write operation has been carried out.
- The total number of devices on which data read/write operations can be carried out at a time is as follows:
 

Read:	1 port (TIM/CNT)
	128 ports (bits other than the above)
	32 ports (bytes/words)
Write:	1 port (bits)
	32 ports (bytes)

#### 2) Usable station numbers and devices

Station numbers

- 01 to 37 (Octal notation)

OIP ID number in M:N connection

- 00 to 255 (Decimal notation)
- Set the OIP master ID number to 255.
- The OIP ID number must not be the same as the PLC ID number.

Devices

- Bit devices

Device name	Range
Input/output relay, general-purpose relay	000000 - 015777
Timer (contact)	T0000 - T0777
Counter (contact)	C0000 - C0777

- Byte devices

Device name	Range
Input/output relay, general-purpose relay	30000 - 31577
TIM/CNT (current data/MD information)	b0000 - b1777
Register	09000 - 99777
Register (for self-diagnostic use)	E0000 - E1777
File register	@000000 - @177777
System memory	#0000 - #2177

- Word devices

Device name	Range
TIM/CNT (current data/MD information)	W0000 - W0777 <sup>(Note)</sup>

Note: For the JW Series, auxiliary information is read out in addition to the current data. The OIP, however, ignores the information.

### 3) OIP connection

#### RS-232C

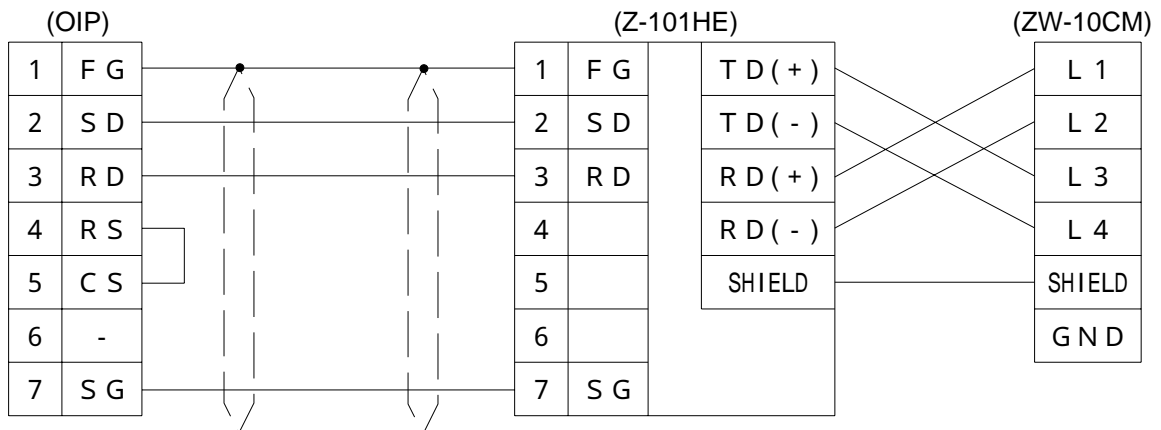

#### RS-422/RS-485 [1:1, 1:N]

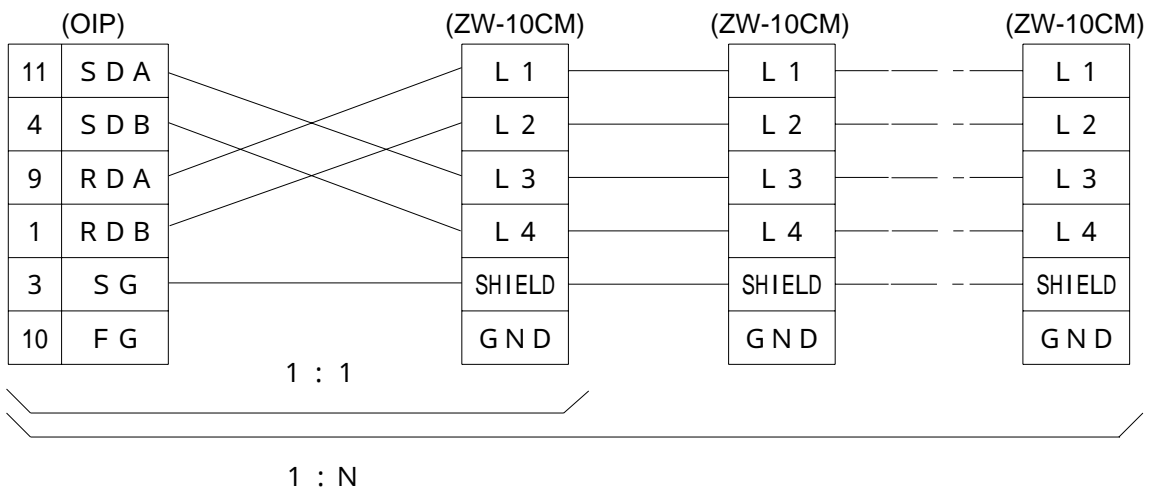

## RS-485 [M:N]

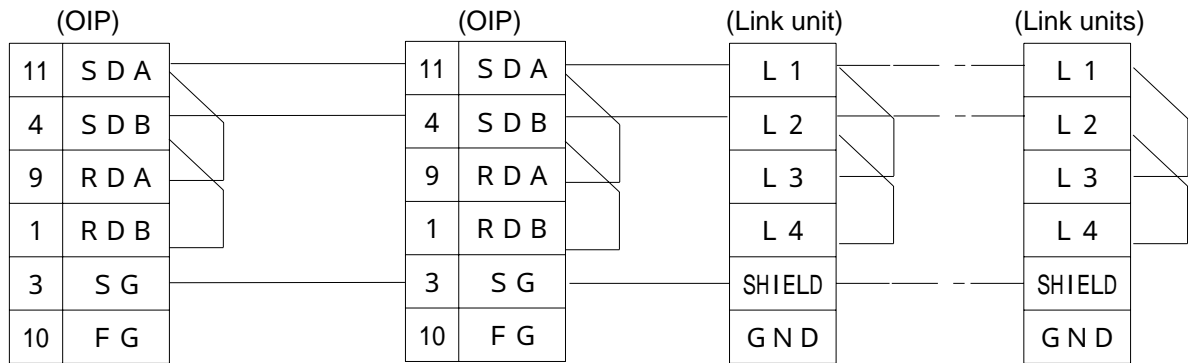



## 5.2 JW (for communication port)

You can communicate by connecting the OIP to the communication port of the control unit. Select [Sharp (Direct connection to CPU)] from the connection devices of the "Project Property" on Screen Creator 5.

For connectable PLC types and link units, refer to Section 2, "List of Connectable PLC Types" of Chapter II.

### 1) Setting a communication function and notes for use



- The communication format must be set in a system memory of the PLC. Refer to the Sharp PLC operating manual for further details of setting.

System memory	Description
#0236	Transmission rate, parity, and stop bits
#0237	Station number, 001(8)-037(8)

- System memoryt (#), TIM-CNT current value, and MD information (w) can be read, but they cannot be written.
- The total number of devices on which data read/write operations can be carried out at a time is as follows:
  - Read: 1 port (TIM/CNT)
  - 128 ports (bits other than the above)
  - 32 ports (bytes/words)
  - Write: 1 port (bits)
  - 32 ports (bytes)

### 2) Usable station numbers and devices

#### Station numbers

- 01 to 37 (Octal notation)

#### OIP ID number in M:N connection

- 00 to 255 (Decimal notation)
- Set the OIP master ID number to 255.
- The OIP ID number must not be the same as the PLC ID number.

#### Devices

- Bit devices

Input/output relay, general-purpose relay	000000 - 015777
Timer (contact)	T0000 - T0777
Counter (contact)	C0000 - C0777

- Byte devices

Device name	Range
Input/output relay, general-purpose relay	30000 - 31577
TIM/CNT (current data/MD information)	b0000 - b1777
Register	09000 - 99777
Register (for self-diagnostic use)	E0000 - E1777
File register	@000000 - @177777
System memory	#0000 - #2177

- Word devices

Device name	Range
TIM/CNT (current data/MD information)	W0000 - W0777 <sup>(Note)</sup>

Note: For the JW Series, auxiliary information is read out in addition to the current data. The OIP, however, ignores the information.

### 3) OIP connection

RS-232C

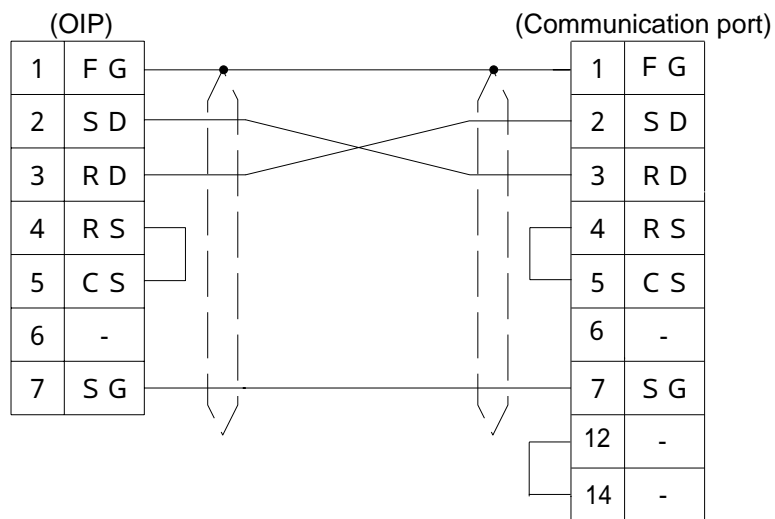

RS-422/RS-485 [1:1, 1:N]

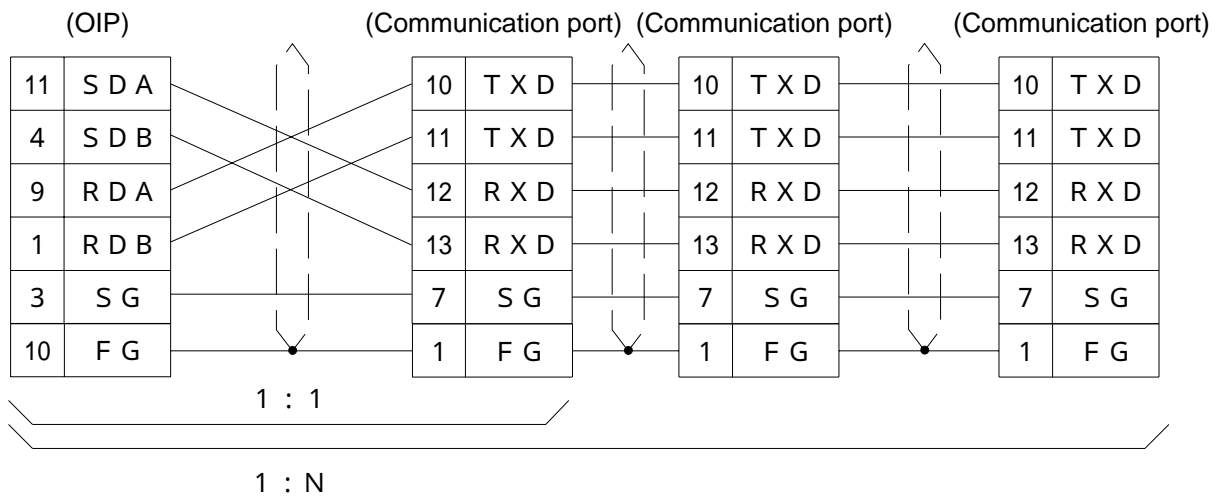

RS-485 [M:N]

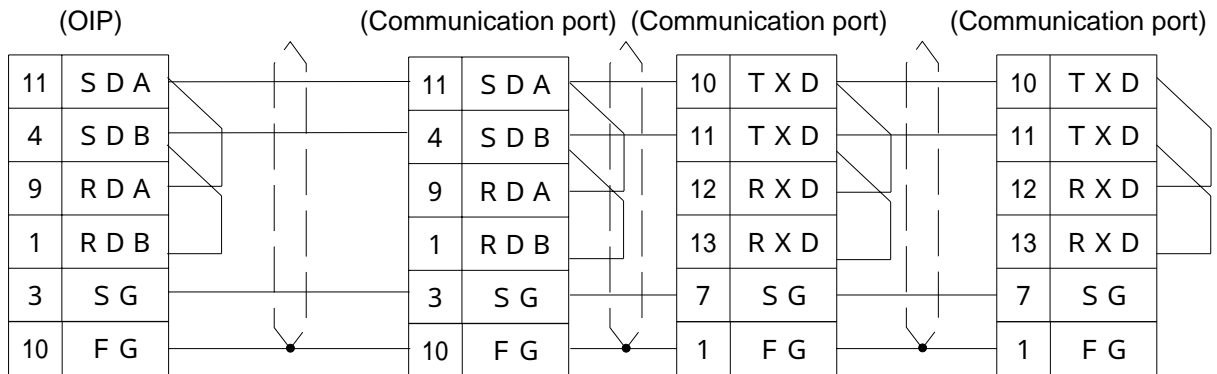

## 6. PLC Supplied by Toyota Koki

### 6.1 TOYOPUC PC1 Series

Select [Toyota Koki (PC1)] from the connection devices of the “Project Property” on Screen Creator 5. For connectable PLC types and link units, refer to Section 2, “List of Connectable PLC Types” of Chapter II.

#### 1) Setting a communication module and notes for use



- Communication procedure: Use transmission format for the computer link.
- The total number of devices on which data read/write operations can be carried out at a time is as follows:
 

Read:	8 ports (bit devices)
	64 ports (byte devices)
Write:	1 port (bit devices)
	8 ports (input/output port of byte devices)
	64 ports (data register of byte devices)

#### 2) Usable station numbers and devices

Station numbers

- 00 to 37 (Octal notation)

Devices

- Bit devices

Device name	Range
Input/output port	0000 - 3777

- Byte devices

Device name	Range
Input/output port	0000B - 3770B
Data register	004000 - 007777

### 3) OIP connection

RS-485 (3-wire) [1 : 1, 1 : N]

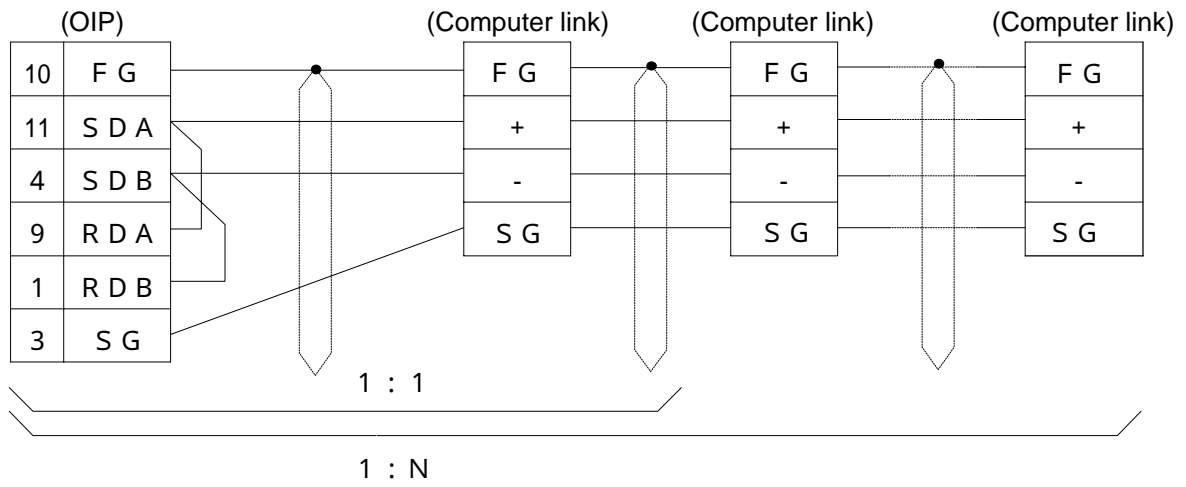

## 6.2 TOYOPUC PC2 Series

Select [Toyota Koki (PC2)] or [Toyota Koki (PC2) (High-speed communication)] from the connection devices of the “Project Property” on Screen Creator 5. “Toyota Koki (PC2) (High-speed communication)” provides high-speed communication, since it registers as many devices as possible in the PLC. Select [Toyota Koki (PC2)] when the multi-panel unit ???21NU-1 is used or M:N connection is performed.

For connectable PLC types and link units, refer to Section 2, “List of Connectable PLC Types” of Chapter II.

### 1) Setting a communication module and notes for use



- Module classification: Set to the computer link.
- The total number of devices on which data read/write operations can be carried out at a time is as follows:
 

Read:	128 ports (bit devices)
	58 ports (word devices)
Write:	1 port (bit devices)
	58 ports (word devices)

### 2) Usable station numbers and devices

#### Station numbers

- 00 to 37 (Octal notation)

#### OIP ID number in M:N connection

- 00 to 09, 16 to 25, 32 to 41, 48 to 57, 64 to 73, 80 to 89, 96 to 105, 112 to 119 (Decimal notation)
- Set the OIP master ID number to 119.
- The OIP ID number must not be the same as the PLC ID number.

#### Devices

- Bit devices

Device name	Range
Input	X0000 - X07FF
Output	Y0000 - Y07FF
Internal relay	M0000 - M07FF
Keep relay	K0000 - K02FF
Special relay	V0000 - V00FF
Timer	T0000 - T01FF
Counter	C0000 - C01FF
Link relay	L0000 - L07FF
Edge relay	P0000 - P01FF

- Word devices

Device name	Range
Data register	D0000 - D2FFF
Link register	R0000 - R07FF
Register (current data)	N0000 - N01FF
Special register	S0000 - S03FF
File register	B0000 - B1FFF

### 3) OIP connection

RS-485 (3-wire) [1 : 1, 1 : N, M:N]

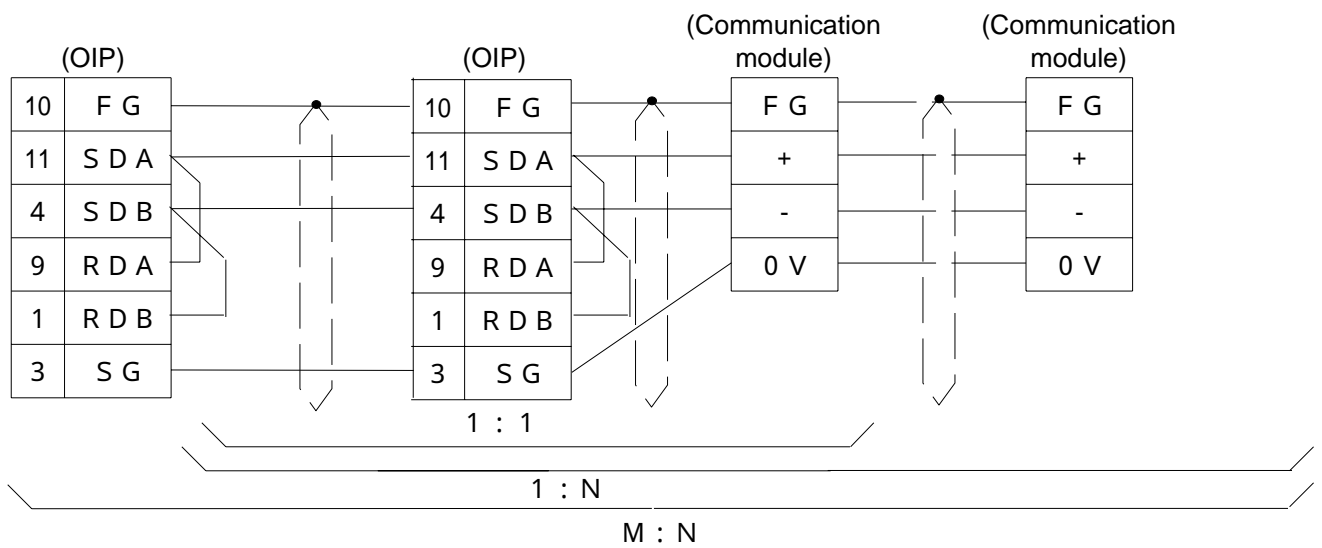

RS-485 (5-wire) [1 : 1, 1 : N, M:N]

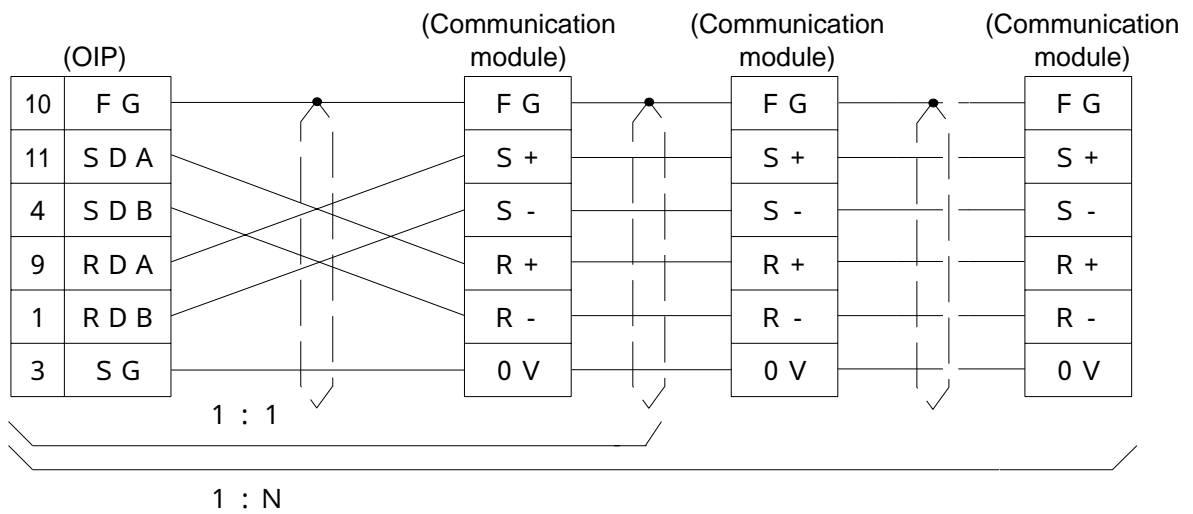

## 6.3 TOYOPUC PC3 Series

---

Select [Toyota Koki (PC3)] from the connection devices of the “Project Property” on Screen Creator 5. For connectable PLC types and link units, refer to Section 2, “List of Connectable PLC Types” of Chapter II.

### 1) Setting a computer link module and notes for use



- Communication procedure: Use PC3 extended communication format.
- The total number of devices on which data read/write operations can be carried out at a time is as follows:
 

Read:	128 ports (bit devices)
	128 ports (byte devices)
	64 ports (word devices)
Write:	1 port (bit devices)
	128 ports (byte devices)
	64 ports (word devices)
- To specify program number, “.” is used in selecting a device.  
 Example: In case of Station Number: 00, Program Number: 2, Device Name: M100, 00-2. M100  
 In case of no specified program number, data is created by setting the minimum value of program number automatically.  
 Example: 00-M100 00-1. M100  
 In case of device that has only one program number, data is created by setting that program number automatically.

### 2) Usable station numbers and devices

#### Station numbers

- 00 to 37 (Octal notation)

#### OIP ID number in M:N connection

- 00 to 09, 16 to 25, 32 to 41, 48 to 57, 64 to 73, 80 to 89, 96 to 105, 112 to 119 (Decimal notation)
- Set the OIP master ID number to 119.
- The OIP ID number must not be the same as the PLC ID number.



## Devices

## • Bit devices

Device name	Program no.	Range
Input	1,2,3	X0000 - X07FF
Output	1,2,3	Y0000 - Y07FF
Internal relay	1,2,3	M0000 - M07FF
Keep relay	1,2,3	K0000 - K02FF
Special relay	1,2,3	V0000 - V00FF
Timer	1,2,3	T0000 - T01FF
Counter	1,2,3	C0000 - C01FF
Link relay	1,2,3	L0000 - L07FF
Edge relay	1,2,3	P0000 - P01FF
Input (extension area)	0	EX0000 - EX07FF
Output (extension area)	0	EY0000 - EY07FF
Internal relay (extension area)	0	EM0000 - EM1FFF
Keep relay (extension area)	0	EK0000 - EK0FFF
Special relay (extension area)	0	EV0000 - EV0FFF
Timer (extension area)	0	ET0000 - ET07FF
Counter (extension area)	0	EC0000 - EC07FF
Link relay (extension area)	0	EL0000 - EL1FFF
Edge relay (extension area)	0	EP0000 - EP0FFF

How to express the word of bit device: Remove the least bit of a bit device and add a letter W.

Example: To express M0100 - M010F as word, represent it in M0010W.

How to express the byte of bit device: Remove the least bit of a bit device and add a letter H or L.

Example: To express M0100 - M0107 as byte, represent it in M0010L.

To express M0108 - M010F as byte, represent it in M0010H.

## • Word devices

Device name	Program no.	Range
Data register	1,2,3	D0000 - D0FFF
Link register	1,2,3	R0000 - R07FF
Register (current value)	1,2,3	N0000 - N01FF
Special register	1,2,3	S0000 - S03FF
File register	1	B0000 - B0FFF
Data register (extension area)	8	U0000 - U7FFF
Register (set value) (extension area)	0	H0000 - H07FF
Register (current value) (extension area)	0	EN0000 - EN07FF
Special register (extension area)	0	ES0000 - ES07FF

How to express the bit of word device: Add "." to the end of a word device and specify a bit.

Example: To express the least bit of D0100, represent it in D0100.0

To express the high order bit of D0100, represent it in D0100.F.

How to express the byte of word device: Add a letter H or L to the end of work device.

Example: To express the least byte of D0100, represent it in D0100L.

To express the high order byte of D0100, represent it in D0100H.

### 3) OIP connection RS-485 (3-wire) [1:1, 1:N, M:N]

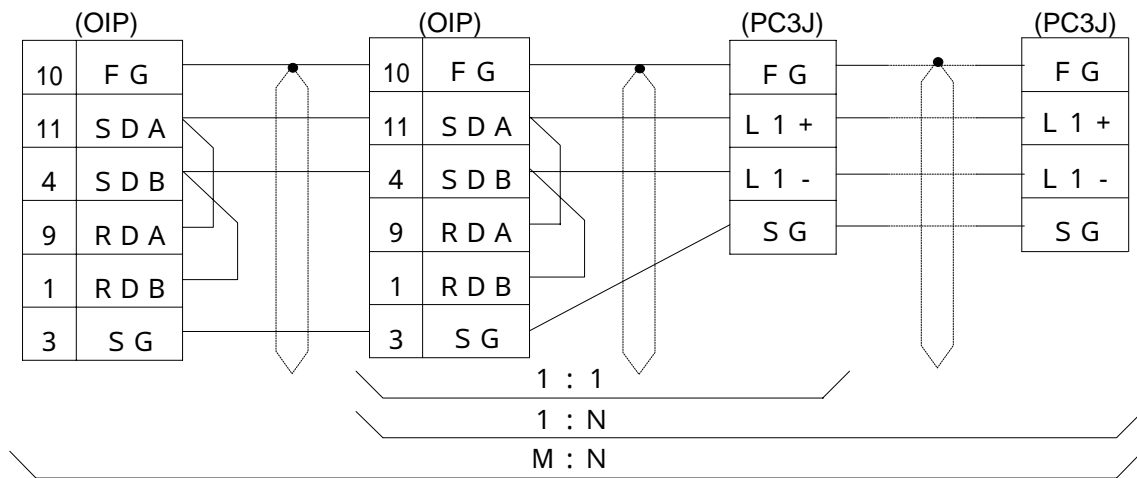



## 7. PLC Supplied by Yasukawa

### 7.1 GL Series, U84, CP-9200

Select [Yasukawa (ASCII)] or [Yasukawa (RTU)] from the connection devices of the “Project Property” on Screen Creator 5. The number of devices which can be read or written at a time differs with “Yasukawa (ASCII)” and “Yasukawa (RTU)”.

For connectable PLC types and link units, refer to Section 2, “List of Connectable PLC Types” of Chapter II.

#### 1) Setting a communication module and notes for use



- Protocol: For Yasukawa ((ASCII), use the ASCII mode of the MEMOBUS slave.  
Data length, therefore, becomes fixed at 7 bits.  
For Yasukawa (RTU), use the RTU mode of the MEMOBUS slave. Data length becomes fixed at 8 bits.
- The total number of devices on which data read/write operations can be carried out at a time is as follows:
 

In case of Yasukawa (ASCII),	
Read/write:	128 ports (bit devices) 32 ports (word devices)
In case of Yasukawa (RTU),	
Read/write:	128 ports (bit devices) 100 ports (word devices)

#### 2) Usable station numbers and devices

Station numbers

- 001 to 247 (Decimal notation)

Devices

- Bit devices

Device name Range	
Coil	00001 - 09999
Input relay	10001 - 19999

- Word devices

Device name	Range
Input register	30001 - 39999 <small>(Note)</small>
Hold register	40001 - 49999



- For the GL60S, 31xxx is a constants register, but this register cannot be used with the OIP.
- The OIP accepts five-digit numbers, though recent PLC devices have six-digit numbers. When such a PLC device is used, convert a six-digit number into

**five digits and input a five-digit number using Screen Creator 5.**  
 e.x. 401234 41234

3) OIP connection

Connection to the MEMOBUS port (RS-232C) [1:1]

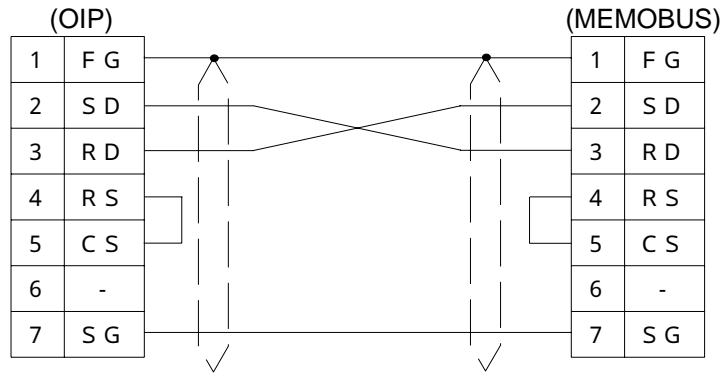

Connection to a modem [1:1, 1:N]

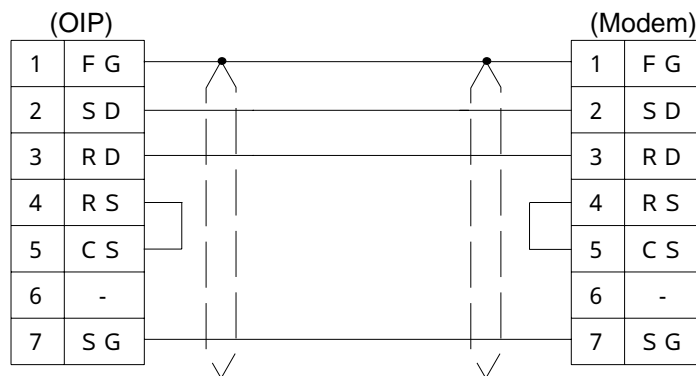

Connection to the MEMOBUS port (RS-422) [1:1, 1:N]

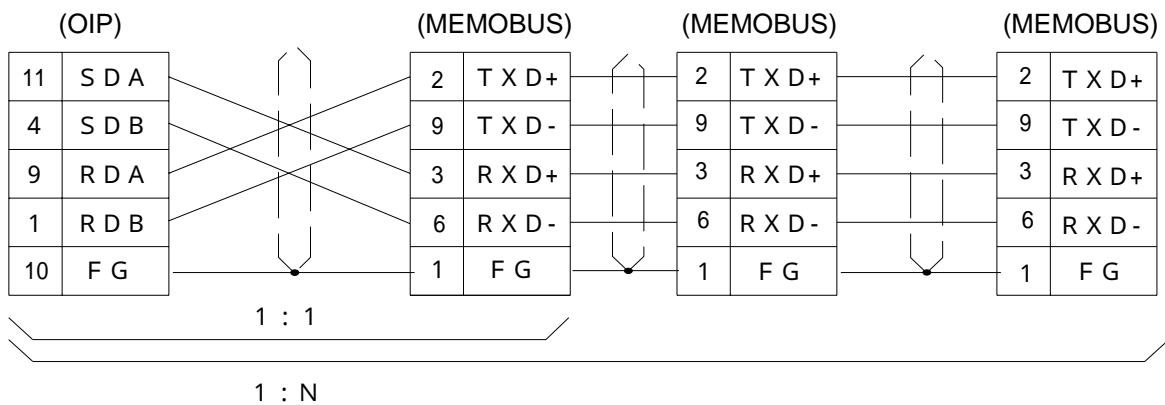

Connection to the CP-2171F port (RS-485) [1:1, 1:N]

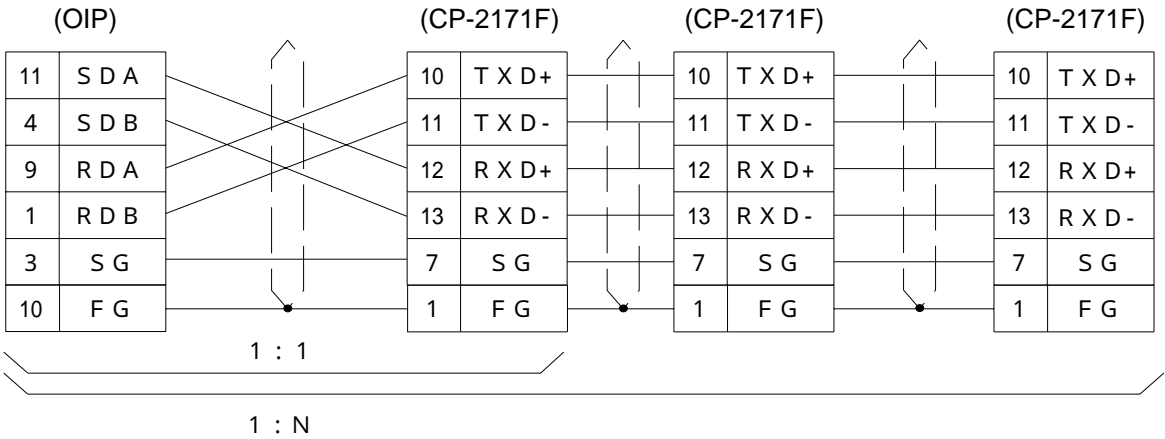

## 7.2 Inverter (VS-616G5)

Select [Yasukawa (Inverter)] from the connection devices of the "Project Property" on Screen Creator 5.

### 1) Setting a communication module and notes for use



- Protocol: For Yasukawa (Inverter), use the RTU mode of the MEMOBUS slave. Data length becomes fixed at 8 bits.
- When using register number, enter it by converting into a hold register number in RTU mode, as shown below.  
Hold register number = Register number (conversion hexadecimal into decimal) + 40001  
Example: The hold register number for the register number (006B) is 40108.
- The total number of devices on which data read/write operations can be carried out at a time is as follows:
 

Read/write:	128 ports (bit devices)
	16 ports (word devices)

### 2) Usable station numbers and devices

Station numbers

- 001 to 247 (Decimal notation)

Devices

- Bit devices

Device name	Range
Hold register	40001 - 49999

### 3) OIP connection

Connection to the RS-232C or RS-485 conversion card SI-K2 [1:1, 1:N]

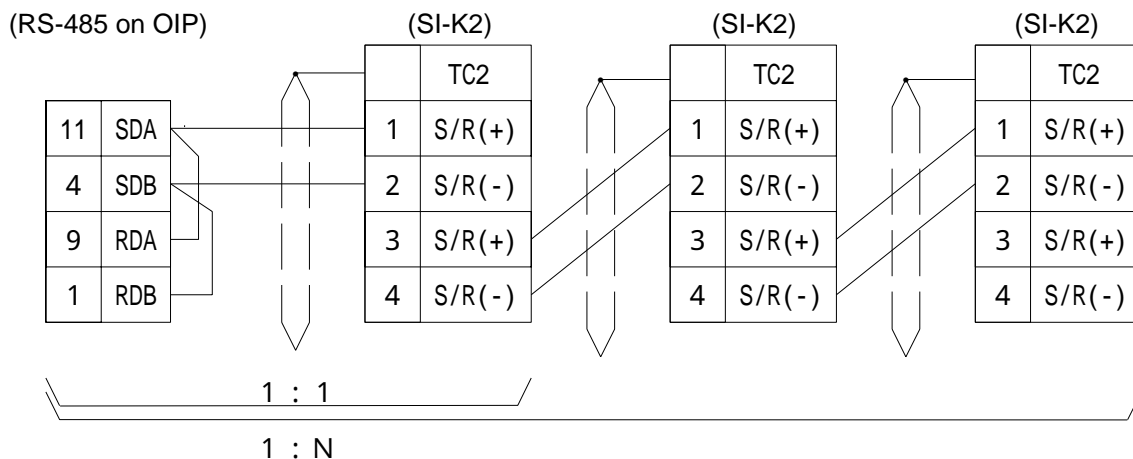

## 8. PLC Supplied by Yokogawa

### 8.1 FA500, FA-M3 (CPU No. fixed)

Depending on the particular CPU number, select either [Yokogawa (CPU\_No.1)], [Yokogawa (CPU\_No.1) (High-speed communication)], [Yokogawa (CPU\_No.2)], [Yokogawa (CPU\_No.2) (High-speed communication)], [Yokogawa (CPU\_No.3)], [Yokogawa (CPU\_No.3) (High-speed communication)], [Yokogawa (CPU\_No.4)], [Yokogawa (CPU\_No.1) (High-speed communication)], from the connection devices of the "Project Property" on Screen Creator 5. "Yokogawa (CPU No. \*) (High-speed communication)" provides high-speed communication, since it registers as many devices as possible in the PLC. Select "Yokogawa (CPU No. \*)" when the multi-panel unit ???21NU-1 is used or M:N connection is performed.

If you want to specify CPU numbers freely, refer to Section 8.2, "FA500, FA-M3, and UT-2000 (CPU No. variable)".

For connectable PLC types and link units, refer to Section 2, "List of Connectable PLC Types" of Chapter II.

#### 1) Setting a link unit and notes for use



- Sum check: Fix at [Yes].
  - Terminator code: Fix at [Yes].
  - Only the value of [EC1] is sent in return as an error code. Be careful, therefore, that an error code of [EC2] is ignored.
  - Any CPU number from 01 to 04 can be selected. Use one CPU number for one system. Even if more than one CPU are present, it is not possible to select 01 at one time and 02 at another time.
  - No data can be written in bit devices (X, Y, L, and M) and word devices (W and Z).
  - When a special module is to be used, enter the following data.  
"Station No". "CPU No". "unit No". x 100 + slot No". "channel No".  
Example: If station number = 01, unit number = 2, slot number = 04, and channel number = 1234, enter the data as shown below.  
01`204.1234
- The total number of digits for unit number + slot number must be 3. Neither default value nor zero-suppression can be specified for these 3 digits.
- The total number of devices on which data read/write operations can be carried out at a time is as follows:
    - Read/write: 128 ports (bit devices)
    - 64 ports (word devices / channel)

#### 2) Usable station numbers and devices

Station numbers

- 01 to 32 (Decimal notation)

OIP ID number in M:N connection

- 00 to 255 (Decimal notation)
- Set the OIP master ID number to 255.
- The OIP ID number must not be the same as the PLC ID number.



## Devices

## • Bit devices

Device name	Range
Input relay	X00101 - X71664
Output relay	Y00101 - Y71664
Internal relay	I00001 - I99999
Sharable relay	E00001 - E99999
Link relay	L00001 - L99999
Special relay	M00001 - M99999

## • Word devices

Device name	Range
Timer	T0001 - T9999
Counter	C0001 - C9999
Data register	D00001 - D99999
Common register	B00001 - B99999
Link register	W00001 - W99999
Special register	Z00001 - Z99999
Index register	V01 - V99
Sharable register	R00001 - R99999

## • Channels

Device name	Range
Channel No.	0000 - 9999



This system is designed so that devices that are not supported at present can also be declared to cope with the system expansion in the future. When any devices are to be used, check the device range of your PLC carefully.

## 3) OIP connection

RS-232C [FA500]

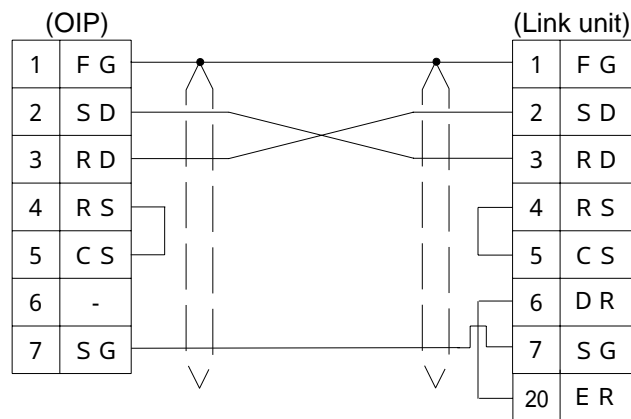

RS-232C [FA-M3]

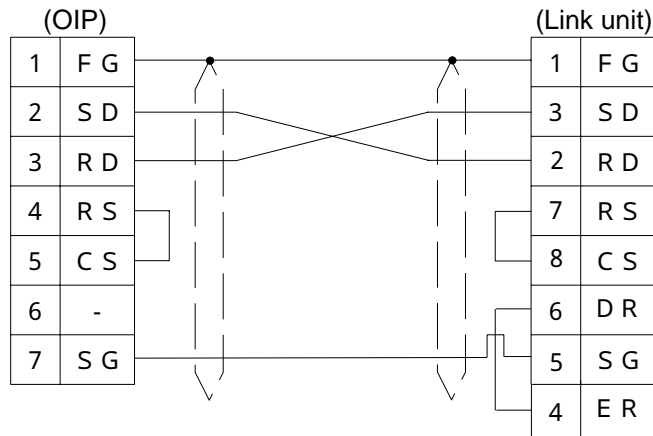

When connecting FA-M3, be careful to select the number of SD or RD.

RS-232C [FA-M3:CPU port]

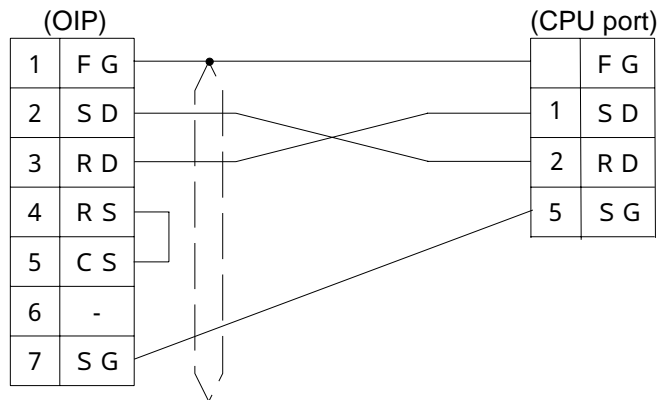

RS-485 [1:1, 1:N]

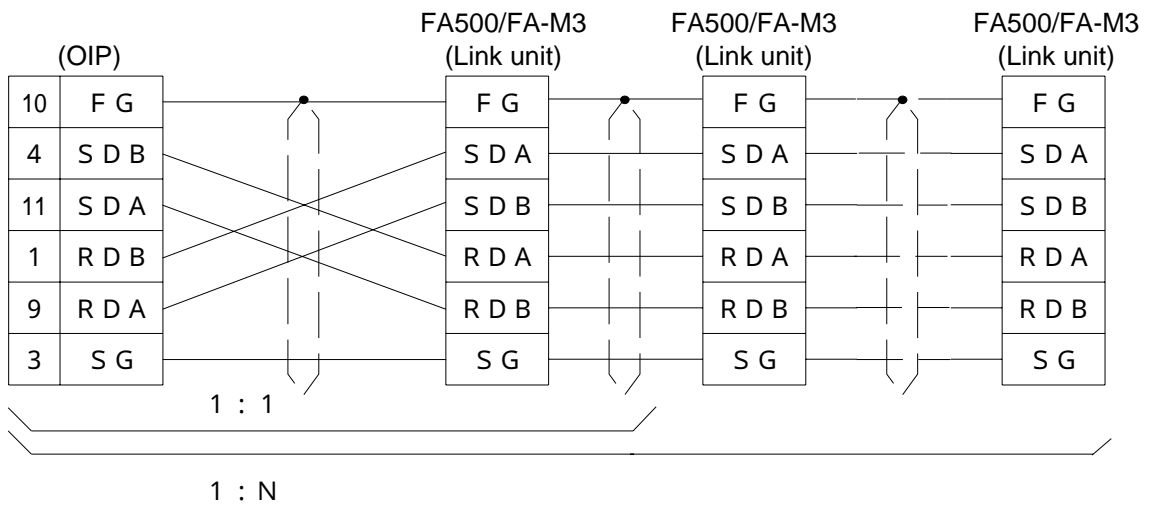

RS-485 [M:N]

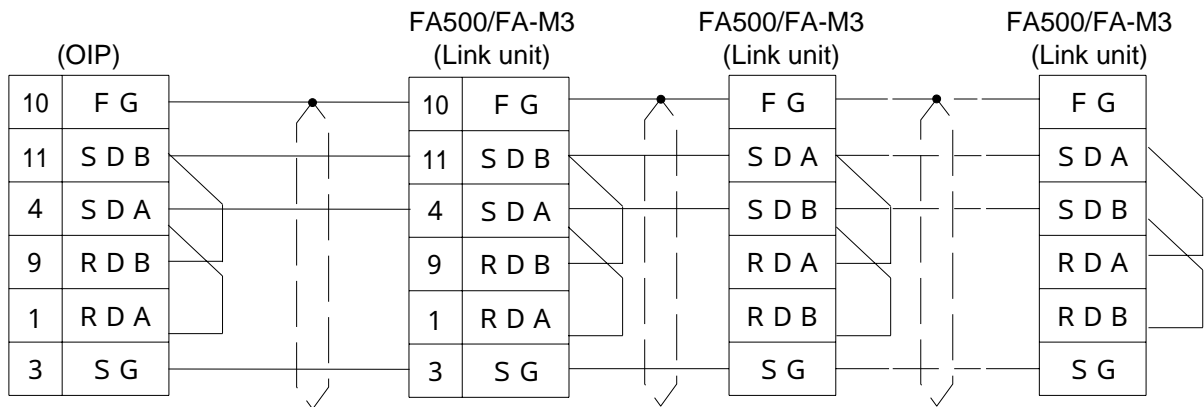

## 8.2 FA500, FA-M3, UT2000 (CPU No. variable)

Select [Yokogawa (CPU No. variable)] or [Yokogawa (CPU No. variable) (High-speed communication)] from the connection devices of the “Project Property” on Screen Creator 5.

Several CPU numbers can be selected from one system. “Yokogawa (Variable CPU No.) (High-speed communication)” provides high-speed communication, since it registers as many devices as possible in the PLC. Select “Yokogawa (CPU No. variable)” when the multi-panel unit ???21NU-1 is used or M:N connection is performed.

For connectable PLC types and link units, refer to Section 2, “List of Connectable PLC Types” of Chapter II.

### 1) Setting a link unit and notes for use



- Sum check: Fix it at [No].
- Terminal character: Fix it at [Yes].
- Only the “EC1” value is returned as an error code. Note that the “EC2” error code is ignored.
- No data can be written in bit devices (X, Y, L, and M) and word devices (W and Z).
- Enter the CPU number as shown below when device names are entered.  
station number CPU number. device name  
With this, multiple CPU numbers can be specified for one system.  
Example: If station number = 01, CPU number = 02, and device name = D1000,  
enter the data as shown below.  
01 02. D1000  
If no CPU number is entered, “01” is assumed as the CPU number automatically to create data.  
Example: 01 D1000 01 01. D1000
- When a special module is to be used, enter the following data.  
“Station No”. “CPU No”. “unit No”. x 100 + slot No”. “channel No”.  
Example: If station number = 01, CPU number = 03, unit number = 2, slot number = 04, and channel number = 1234, enter the data as shown below.  
01 03. 204. 1234  
The total number of digits for unit number + slot number must be 3. Neither default value nor zero-suppression can be specified for these 3 digits.
- The total number of devices on which data read/write operations can be carried out at a time is as follows:  
Read/write: 128 ports (bit devices)  
64 ports (word devices / channel)

### 2) Usable station numbers and devices

Station numbers

- 01 to 32 (Decimal notation)

OIP ID number in M:N connection

- 00 to 255 (Decimal notation)
- Set the OIP master ID number to 255.
- The OIP ID number must not be the same as the PLC ID number.

## Devices

## • Bit devices

Device name	Range
Input relay	X00101 - X71664
Output relay	Y00101 - Y71664
Internal relay	I00001 - I99999
Sharable relay	E00001 - E99999
Link relay	L00001 - L99999
Special relay	M00001 - M99999

## • Word devices

Device name	Range
Timer	T0001 - T9999
Counter	C0001 - C9999
Data register	D00001 - D99999
Common register	B00001 - B99999
Link register	W00001 - W99999
Special register	Z00001 - Z99999
Index register	V01 - V99
Sharable register	R00001 - R99999

## • Channels

Device name	Range
Channel No.	0000 - 9999



This system is designed so that devices that are not supported at present can also be declared to cope with the system expansion in the future. When any devices are to be used, check the device range of your PLC carefully.

## 3) OIP connection

## RS-232C [FA500]

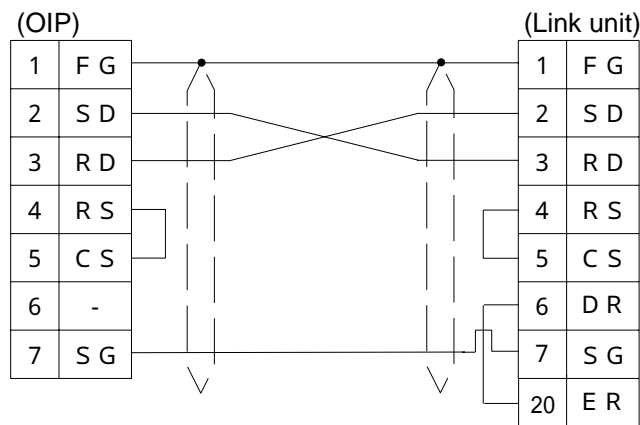

RS-232C [FA-M3]

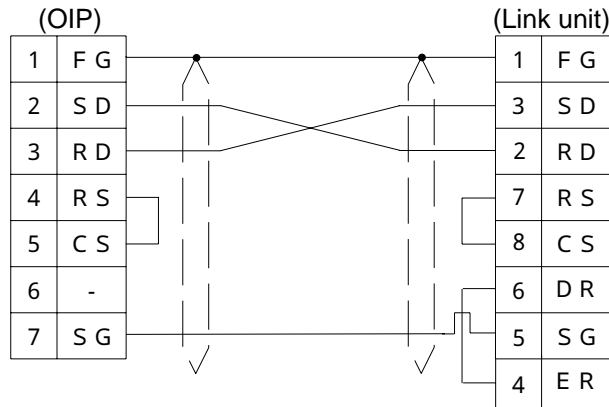

When connecting FA-M3, be careful to select the number of SD or RD.

RS-232C [FA-M3:CPU port]

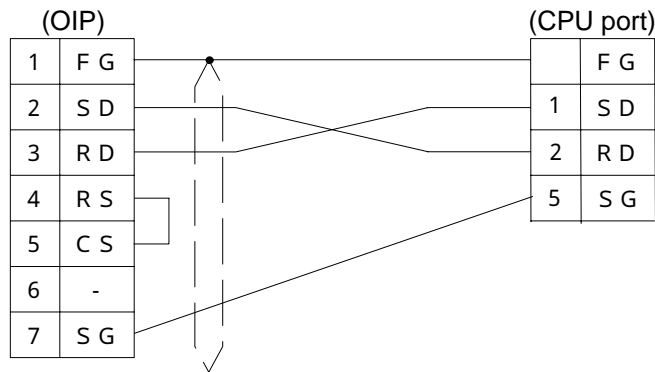

RS-485 [1:1, 1:N]

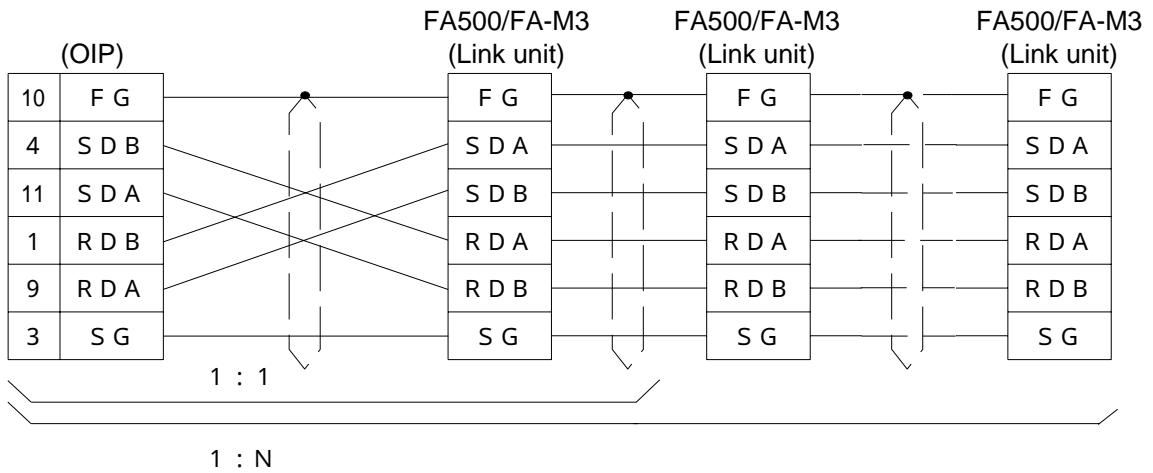

RS-485 [M:N]

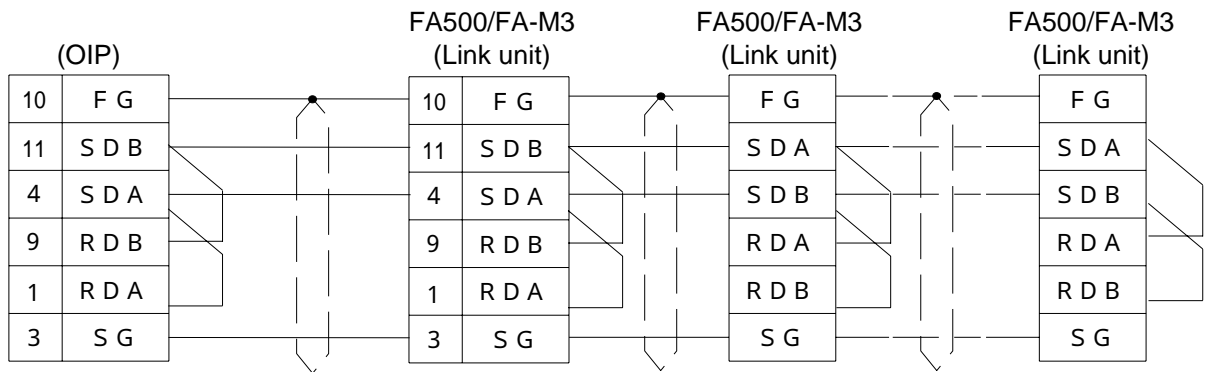

RS-485 [1:1, 1:2]

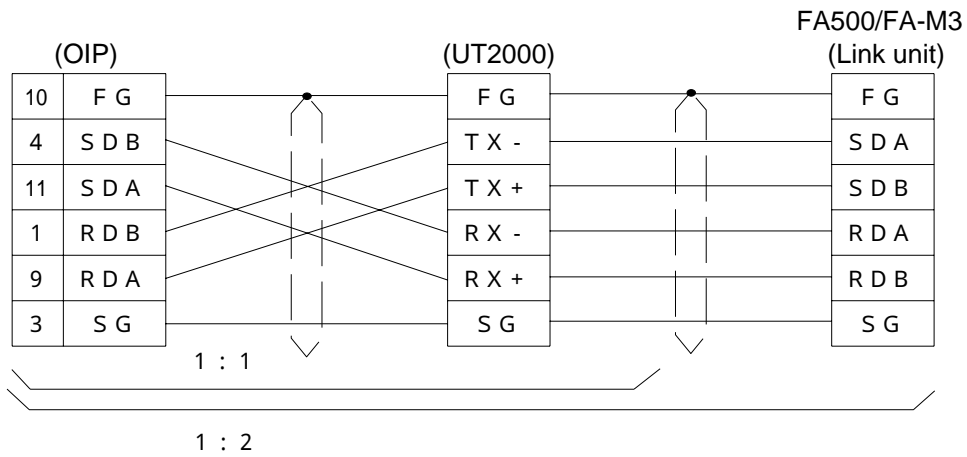

## 9. PLC Supplied by Matsushita

### 9.1 FP Series

Select [Matsushita (FP)] from the connection devices of the "Project Property" on Screen Creator 5. For connectable PLC types and link units, refer to Section 2, "List of Connectable PLC Types" of Chapter II.

#### 1) Setting a communication unit and notes for use



- Communication unit: Use computer linking.
- The total number of devices on which data read/write operations can be carried out at a time is as follows:
 

Read:	128 ports (bit devices)
	24 ports (timer/counter)
	27 ports (word devices other than the above)
Write:	8 ports (bit devices)
	24 ports (word devices)

#### 2) Usable station numbers and devices

Station numbers

- 01 to 63 (Decimal notation)

Devices

- Bit devices

Device name	Range
External input relay	X0000 - X127F
External output relay	Y0000 - Y127F
Internal output relay	R0000 - R097F
Special internal output relay	R9000 - R910F
Link relay	L0000 - L127F

- Word devices

Device name	Range
Data register	DT0000 - DT2047
Special data register	DT9000 - DT9255
File register	FL00000 - FL22524
Link register	LD000 - LD255
Timer/counter (current data)	EV000 - EV255



3) OIP connection

RS-232C

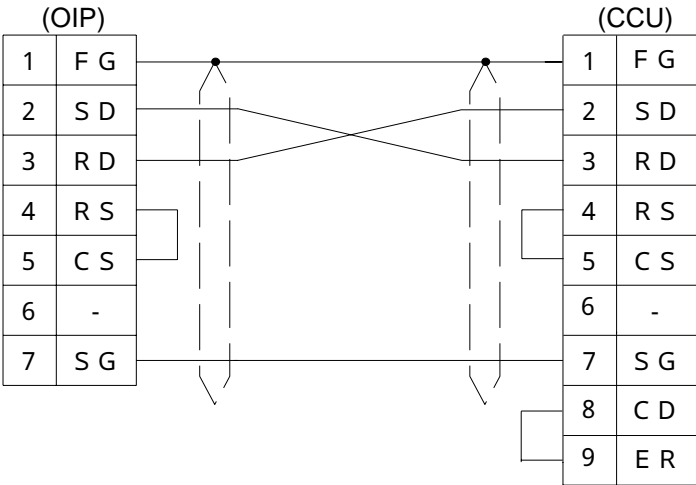

## 10. PLC Supplied by Matsushita

### 10.1 Panadac 700 Series

Select [Matsushita (Panadac 700)] from the connection devices of the “Project Property” on Screen Creator 5.

For connectable PLC types and link units, refer to Section 2, “List of Connectable PLC Types” of Chapter II.

#### 1) Setting a communication link and notes for use



- Communication procedure: Use command service mode.
- The total number of devices on which data read/write operations can be carried out at a time is as follows:
 

Read:	128 ports (bit devices)
	58 ports (lead)
	29 ports (doubled lead)
Write:	30 ports (bit devices)
	58 ports (lead)

#### 2) Usable station numbers and devices

Station numbers

- 00 to FF (Hexadecimal notation)

Devices

- Bit devices (relay device)

Device name	Range
Input/output relay	IN000 - IN7FF OT000 - OT7FF
Internal relay	RL000 - RL7FF
Hold relay	KR000 - KR3FF
Link relay	LK000 - LK7FF
Status relay	ST000 - ST1FF
MC status relay	MS000 - MS3FF
Timer start relay	TS000 - TS1FF
Timer-up relay	TU000 - TU1FF
Count-up relay	CU000 - CU07F
CPU input relay	CI000 - CI1FF
CPU output relay	CO000 - CO1FF

- Word devices (relay device, register device)

Device name	Range
Input/output relay	IN000W - IN07FW OT000W - OT07FW
Internal relay	RL000W - RL07FW
Hold relay	KR000W - KR03FW
Link relay	LK000W - LK07FW
Status relay	ST000W - ST01FW
MC status relay	MS000W - MS03FW
Timer start relay	TS000W - TS01FW
Timer-up relay	TU000W - TU01FW
Count-up relay	CU000W - CU007F
CPU input relay	CI000W - CI01FW
CPU output relay	CO000W - CO01FW
Timer (set value)	TM000 - TM1FW
Timer (current value)	TC000 - TC1FF
Data memory	M0000 - M07FF
Link register	LM000 - LM7FF

- Double word devices (register device)

Device name	Range
Counter value	CT000 - CT07F
Position data	PM000 - PM7FF

### 3) OIP connection

RS-232C

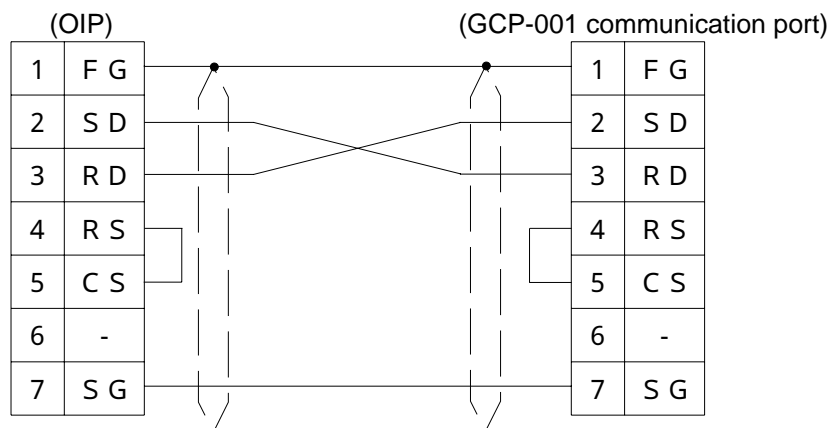

# 11. PLC Supplied by Toshiba

## 11.1 EX Series

Select [Toshiba (EX)] from the connection devices of the “Project Property” on Screen Creator 5. For connectable PLC type and link units, refer to Section 2, “List of Connectable PLC Types” of Chapter II.

### 1) Setting a communication function and notes for use



- Communication function: Provide computer linking.
- The total number of devices on which data read/write operations can be carried out at a time is as follows:
 

Read:	32 ports (bit devices)
Write:	32 ports (word devices)

### 1) Usable station numbers and devices

Station numbers

- 00 to 15 (Decimal notation)

Devices

- Bit devices

Device name	Range
Input relay	X000 - X31F
Output relay	Y000 - Y31F
Auxiliary relay	R000 - R63F
Link relay	Z000 - Z31F

- Word devices

Device name	Range
Input register	XW00 - XW63
Output register	YW00 - YW63
Auxiliary relay register	RW00 - RW63
Link relay register	ZW00 - ZW31
Data register	D0000 - D1535
Timer register	T000 - T127
Counter register	C00 - C95

### 3) OIP connection

#### RS-232C

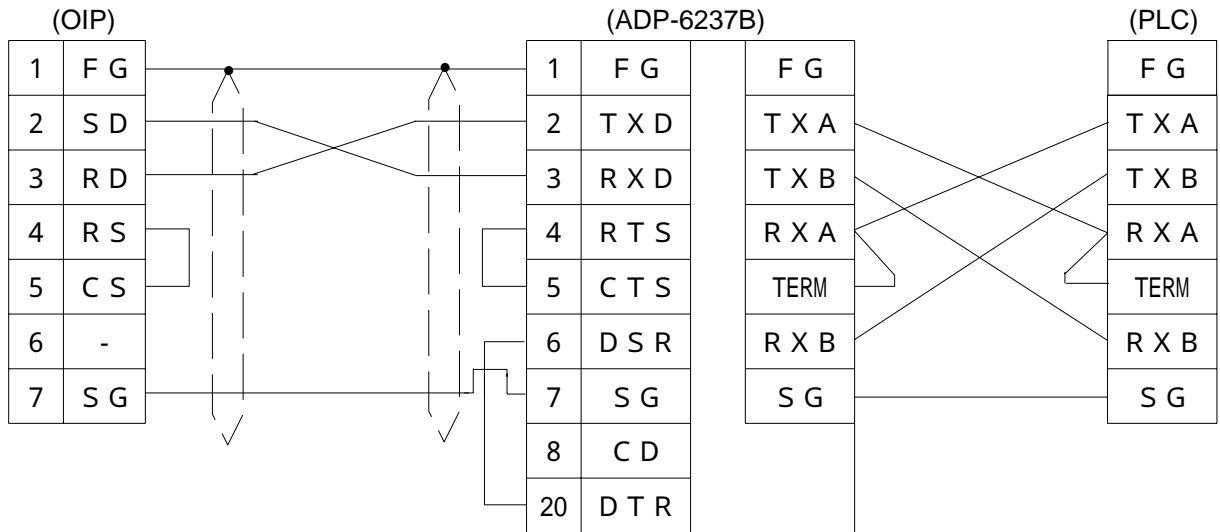

#### RS-485 [1:1, 1:N]

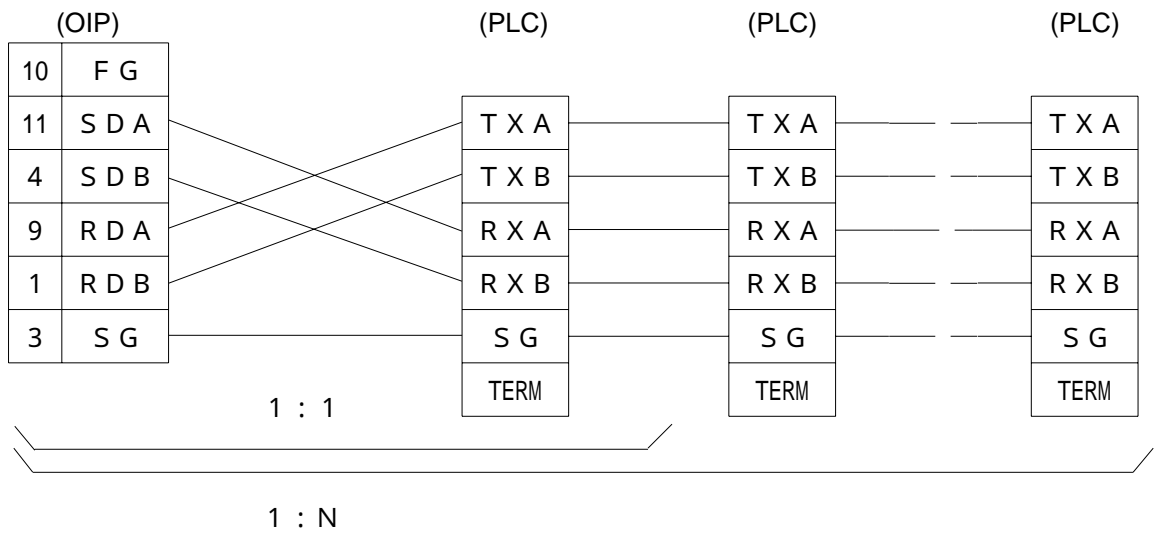

## 11.2 T Series

Select [Toshiba (T)] from the connection devices of the "Project Property" on Screen Creator 5.  
For connectable PLC types and link units, refer to Section 2, "List of Connectable PLC Types" of Chapter II.

### 1) Setting a communication function and operating notes



- Set communication parameters according to the communication specifications of the model to be connected.
- The total number of devices on which data read/write operations can be carried out at a time is as follows:
  - Read/write: 29 ports (timer/counter)
  - 32 ports (bit/word devices other the above)

### 2) Usable station numbers and devices

Station numbers

- 01 to 32 (Decimal notation)

Devices

- Bit devices

Device name	Range
Input relay	X0000 - X255F
Output relay	Y0000 - Y255F
Internal relay	R0000 - R511F
Link relay	L0000 - L255F
Link register relay	Z0000 - Z511F

- Word devices

Device name	Range
Input relay register	XW000 - XW255
Output relay register	YW000 - YW255
Internal relay register	RW000 - RW511
Link relay register	LW000 - LW255
Link register	W0000 - W1023
Data register	D0000 - D8191
Timer register	T000 - T511
Counter register	C000 - C511
File register	F0000 - F8191

### 3) OIP connection

RS-232C

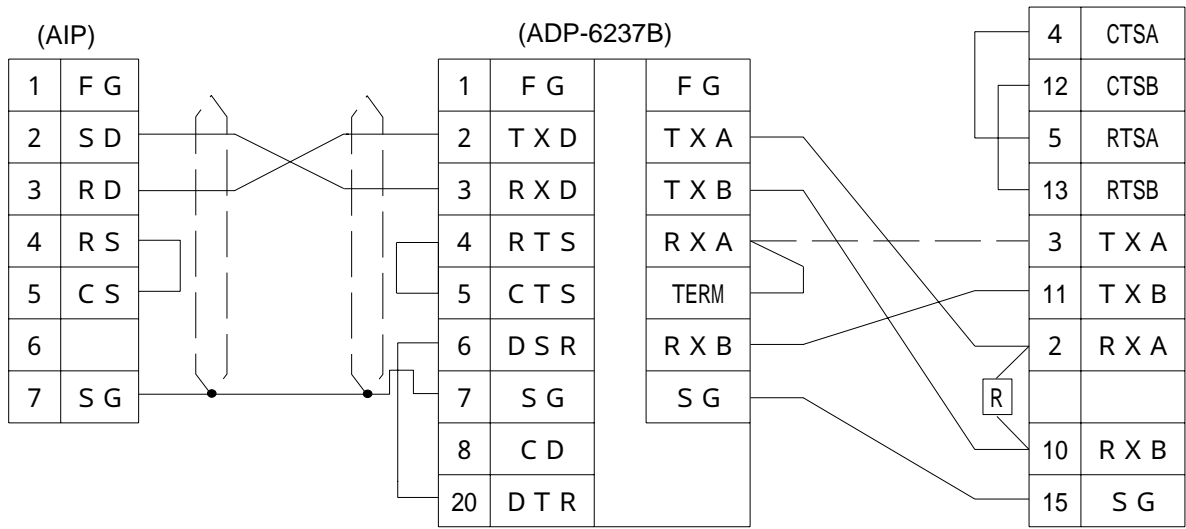

RS-485 [1:1, 1:N]

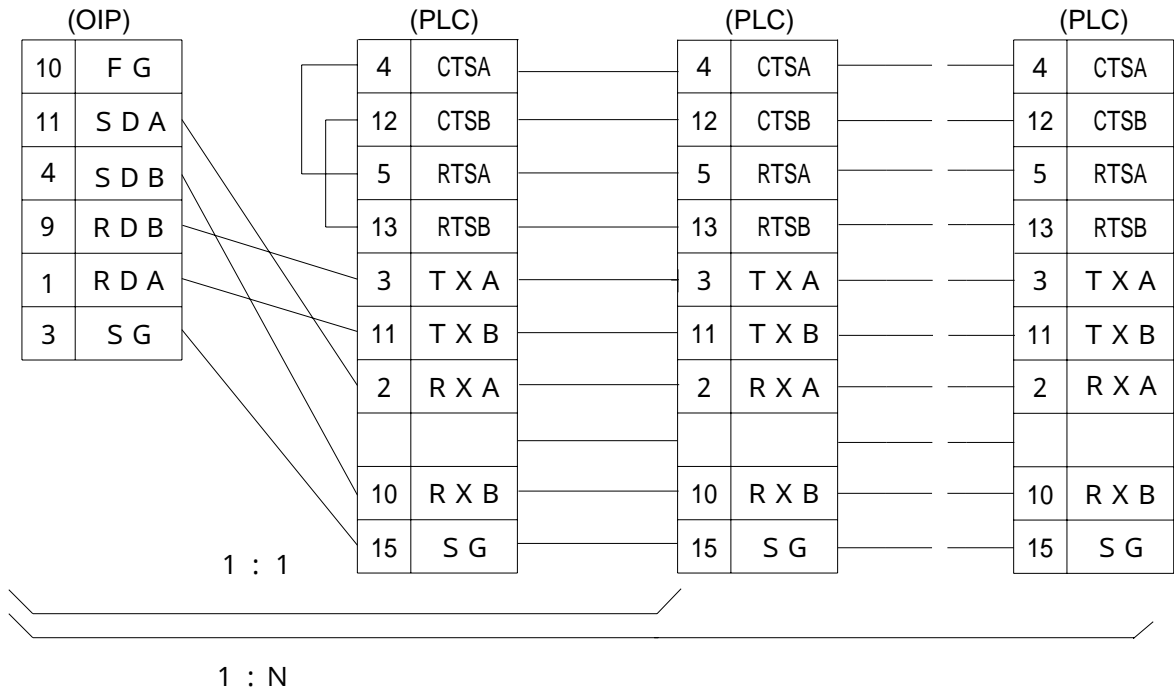

## 12. PLC Supplied by Yamatake-Hoenywell

### 12.1 MA500

Select [Yamatake-Honeywell (MA500)] from the connection devices of the “Project Property” on Screen Creator 5.

For connectable PLC types and link units, refer to Section 2, “List of Connectable PLC Types” of Chapter II.

#### 1) Notes for use



- The total number of devices on which data read/write operations can be carried out at a time is as follows:

Read/write: 128 ports (bit devices)  
20 ports (word devices)

#### 2) Usable station numbers and devices

Station numbers

- 01 to 63 (Decimal notation)

Devices

- Bit devices

Device name	Range
Relay	0000.00 - 4095.15

- Byte devices

Device name	Range
Relay (H)	0000H - 4095H
Relay (L)	0000L - 4095L

- Word devices

Device name	Range
Relay	0000W - 4095W



### 3) OIP connection

RS-232C

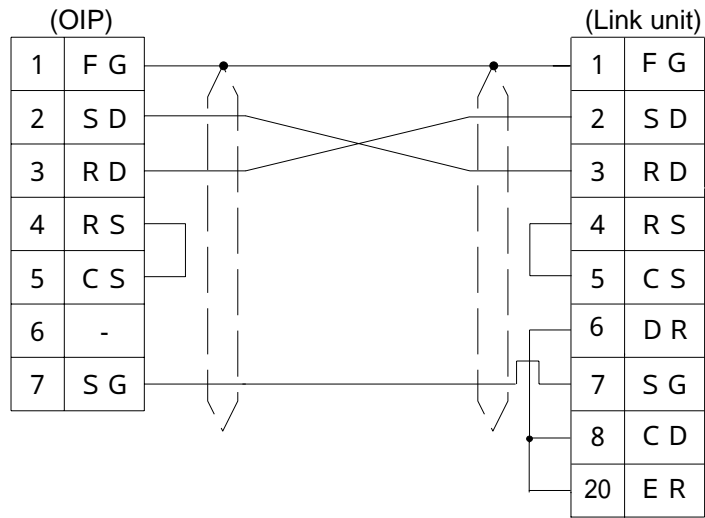

RS-485 [1:1, 1:N]

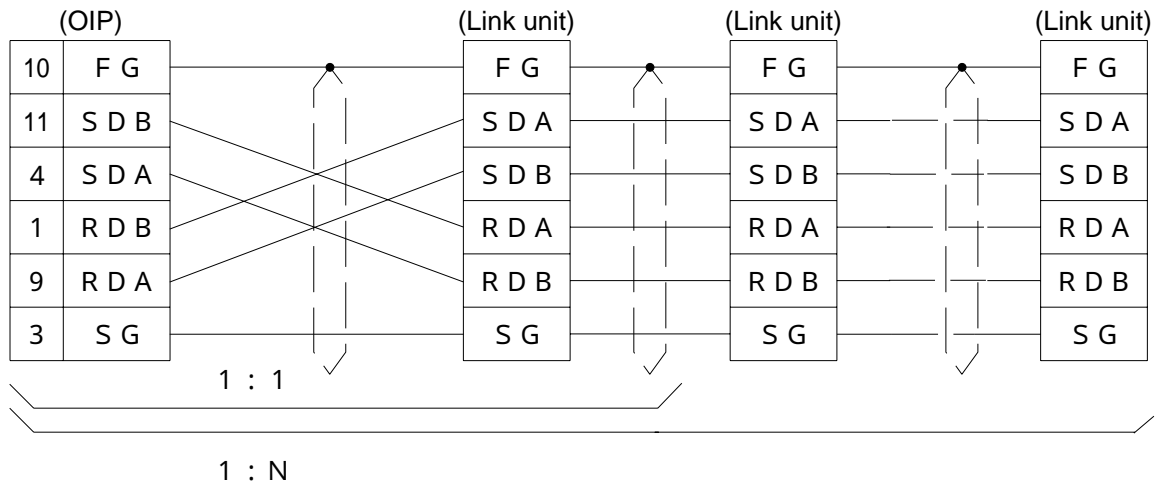

## 13. PLC Supplied by Keyence

### 13.1 KZ300

A Keyence PLC can be connected to this system using a personal computer link unit (KZ-L2). The PLC must be operated in the link mode in that case, however.

Select [Omron (C)] from the connection devices of the "Project Property" on Screen Creator 5. Then, enter Omron device names instead of the current device names.

#### 1) Setting a link unit and notes for use



- Operating mode: Set to the link mode
- Writing is not executed in bit devices one by one. Data is always written word by word. So, "0" is written in all the bits in the same word except in the object one. Values written in bit devices are assured if cyclic communication is made using lamp displays and lamp switches arranged on the same screen. In other cases, use only one bit in the same channel.
- If some bits in a channel are used over screens, values written on another screen cannot be assured.
- Do not use bits as a coil in the same channel on the PLC side. It is recommended to use a different area on PLC and OIP respectively.
- The total number of devices on which data read/write operations can be carried out at a time is as follows:
  - Read/write: 128 ports (bit devices)
  - 28 ports (word devices)

#### 2) Usable station numbers and devices

Station numbers

- 00 to 15 (Decimal notation)

Devices

- Bit devices

Device name	Range	Omron's device name
Input/output relays, Internal auxiliary relay, Special relay	00000 - 17915	00000 - 17915
Temporary data memory	TM0000 - TM3115	HR0000 - HR3115

- Word devices

Device name	Range	Omron's device name
Data memory	DM0000 - DM9999	DM0000 - DM9999
Timer (current value)	T000 - T249	TIM000 - TIM249
Counter (current value)	C000 - C249	CNT000 - CNT249
Fast counter	CTH0, CTH1	CNT254, CNT255
Input/output relays, Internal auxilliary relay, Special relay	000 - 179	000 - 179
Temporary data memory	TM00 - TM31	HR00 - HR31
Trimmer value	Trimmer value: 0, Trimmer value: 1	HR32, HR33

Note 1: Data can only be read/written from/in CTH0 and CTH1 one by one.

Note 2: Only reading is possible from TM30 and TM31.

Note 3: Values in trimmers can only be read, one by one.

RS-232C (Port 1)

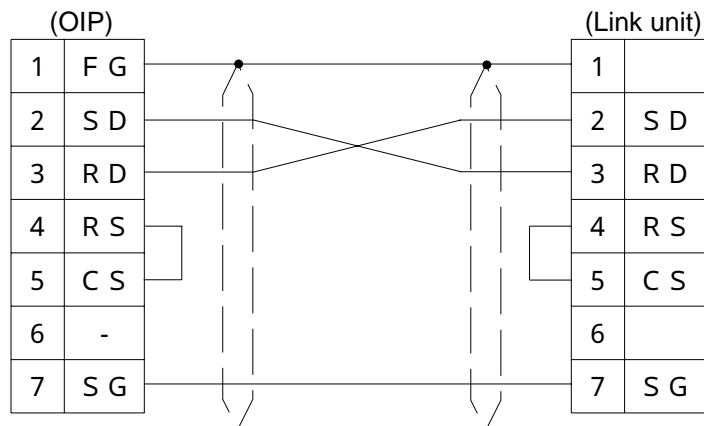

RS-232C (Port 2)

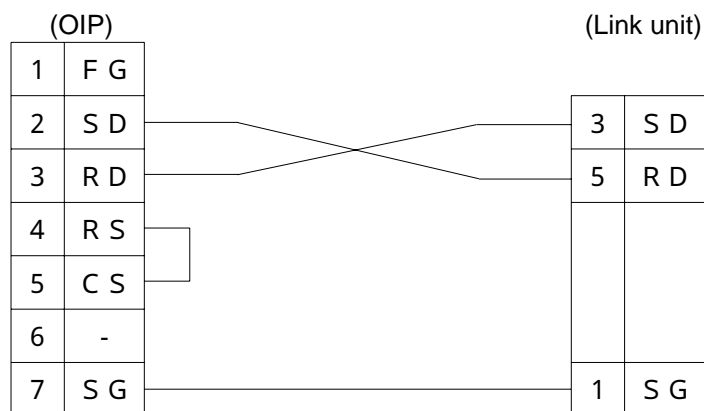

## RS-485 (Port 2)

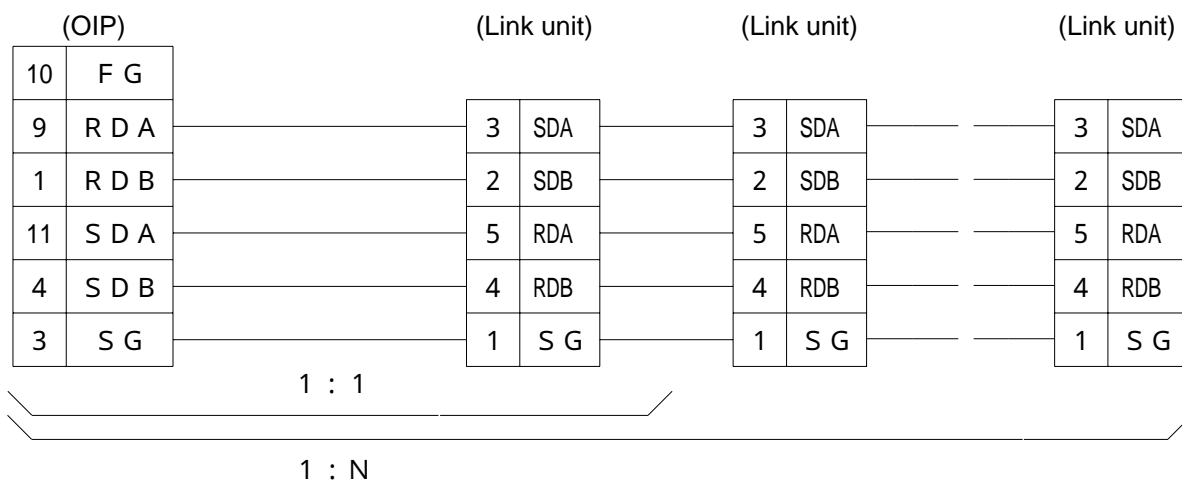

## 13.2 KZ-A500

The KZ-A500 can be connected to this system using a personal computer link unit (KZ-L10). The PLC must be operated in the link mode.

Select [Mitsubishi (AnN/AnS) (LINK)], [Mitsubishi (AnN/AnS) (LINK) (High-speed communication)], [Mitsubishi (AnN/AnU) (LINK)], or [Mitsubishi (AnN/AnU) (LINK) (High-speed communication)] from the connection devices of the "Project Property" on Screen Creator 5.

[Mitsubishi (AnN/AnS) (LINK) (High-speed communication)] or [Mitsubishi (AnN/AnU) (LINK) (High-speed communication)] can provide high-speed communication, since it registers as many devices as possible in the PLC. Select [Mitsubishi Electric (AnN/AnS) (LINK)] or [Mitsubishi (AnN/AnU) (LINK) (High-speed communication)] when the multi-panel unit ???21NU-1 is used.

### 1) Setting a link unit and notes for use



- Operating mode: Set it to Protocol Mode 4.
- Sum check: Fix at [Yes].
- Write Enable/Disable during running: Set to "Enable".
- The number of devices from/in which data can be read/write at a time is as shown below.
 

Read/write:	128 ports (bit devices)
	64 ports (word devices)

### 2) Usable station numbers and devices

#### Station numbers

- 00 to 09 (Decimal notation)

#### Devices

- Bit devices

Device name	Range
Input relay	X000000 - X0007FF
Output relay	Y000000 - Y0007FF
Internal relay	M000000 - M008191
Latch relay	L000000 - L008191
Link relay	B000000 - B000FFF
Annunciator	F000000 - F002047
Special relay	M009000 - M009255
Timer (contact)	TS00000 - TS02047
Timer (coil)	TC00000 - TC02047
Counter (contact)	CS00000 - CS01023
Counter (coil)	CC00000 - CC01023

- Word devices

Device name	Range
Timer-current value	TN00000 - TN02047
Counter-current value	CN00000 - CN01023
Data register	D000000 - D006143
Link register	W000000 - W000FFF
File register	R000000 - R008191
Special register	D009000 - D009255

### 3) OIP connection

#### RS-232C (Port 1)

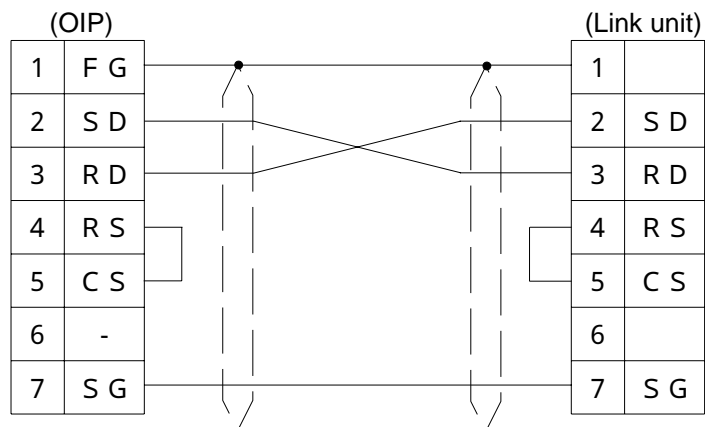

#### RS-232C (Port 2)

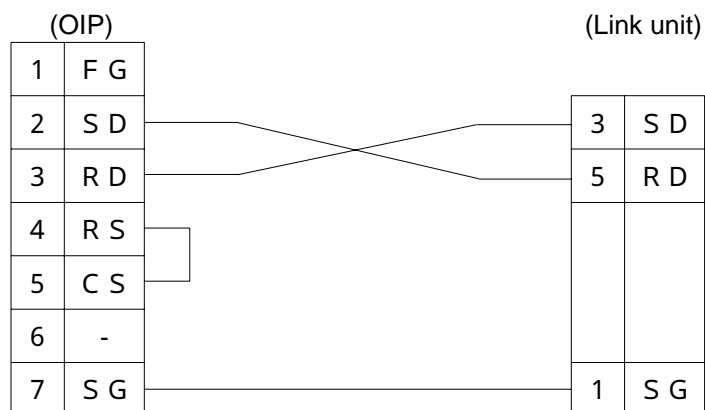

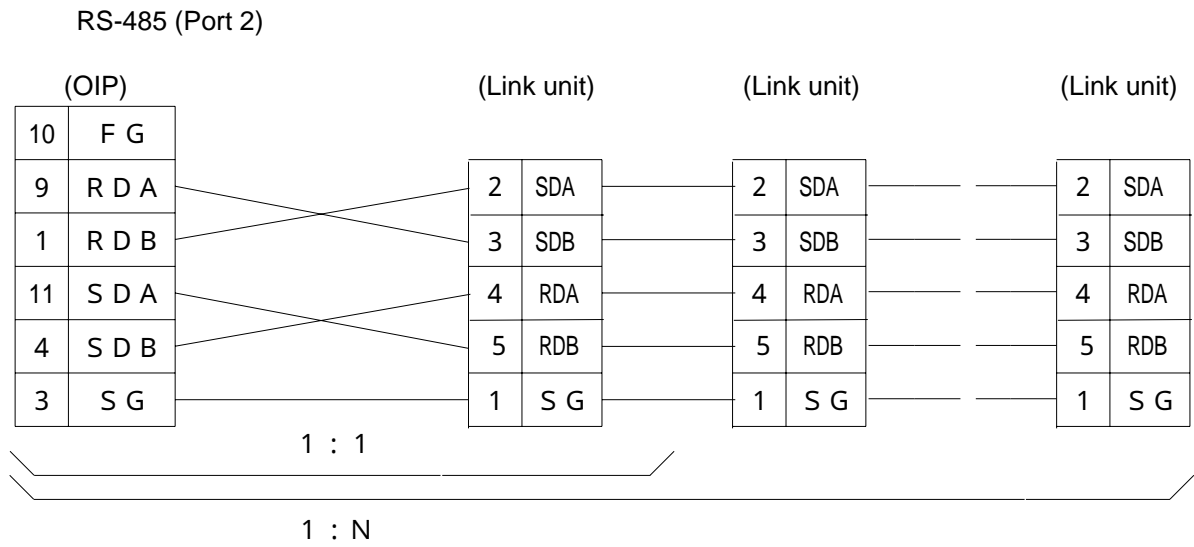

## 14. PLC Supplied by Toyo

### 14.1 $\mu$ -GPCH Series

Select [Toyo ( $\mu$ -GPCH)] from the connection devices of the "Project Property" on Screen Creator 5. For connectable PLC types and link units, refer to Section 2, "List of Connectable PLC Types" of Chapter II.

#### 1) Setting a link unit and notes for use



- Transmission mode: Set to Command mode.
- Network No.: Fix at 00.
- Input relay (I), announcement relay (Z), input register (i), and announcement register (z) can be read out but cannot be written in.
- Writing is not executed in bit devices one by one. Data is always written word by word. So, "0" is written in all the bits in the same word except in the object one. Values written in bit devices are assured if cyclic communication is made using lamp displays and lamp switches arranged on the same screen. In other cases, use only one bit in the same channel.
- If some bits in a channel are used over screens, values written on another screen cannot be assured.
- Do not use bits as a coil in the same channel on the PLC side. It is recommended to use a different area on PLC and OIP respectively.
- The total number of devices on which data read/write operations can be carried out at a time is as follows:
 

Read/write:	128 ports (bit devices)
	58 ports (word devices)

#### 2) Usable station numbers and devices

Station numbers

- 00 to 31 (Decimal notation)

Devices

- Bit devices

Device name	Range
Link relay	G0000 - G1FFFF
Input relay	I00000 - I00FFF
Announcement relay	Z0000 - Z00FFF
Auxilliary relay	B0000 - B017FF



- Word devices

Device name	Range
Link register	g00000 - g01FFF
Input register	i00000 - i000FF
Annoucement register	z00000 - z000FF
Auxilliary register	b00000 - b0017F
Arithmetic register	mi00000 - mi017FF

### 3) OIP connection

RS-232C

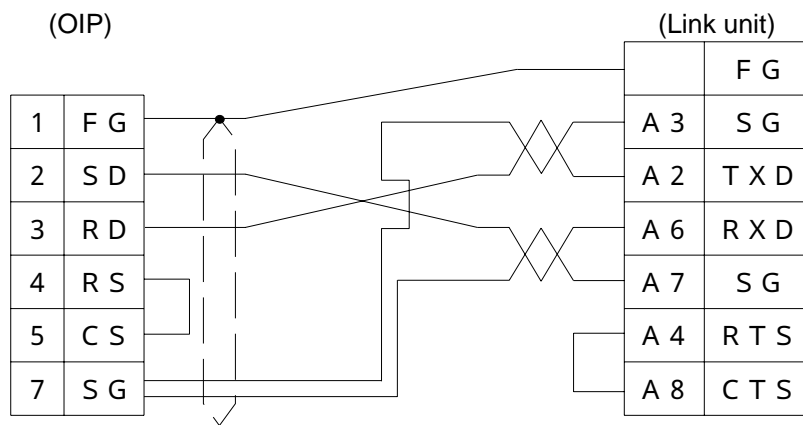

RS-485 [1:1]

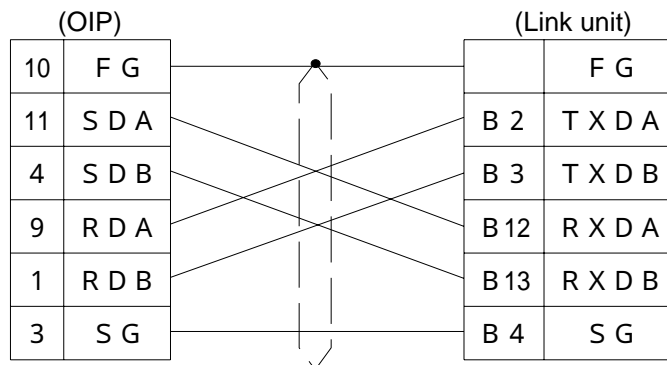

## 15. PLC Supplied by A-B

### 15.1 SLC500

Select [AB (SLC500)] from the connection devices of the "Project Property" on Screen Creator 5. For connectable PLC types and link units, refer to Section 2, "List of Connectable PLC Types" of Chapter II.

#### 1) Setting a link unit and notes for use



- Communication protocol: Set full-duplex DF1.
- Check sum: Fix it at "BCC".
- No data can be written in bit devices except for B (bit).
- Writing in B (bit) is made word by word. Thus, "0" is written in all the bits except for the object one.  
Values written in bit devices are assured if cyclic communication is made using lamp displays and lamp switches arranged on the same screen. In other cases, use only one bit in the same channel.
- If some bits in a channel are used over screens, values written on another screen cannot be assured.
- Do not use bits as a coil in the same channel on the PLC side. It is recommended to use a different area on PLC and OIP respectively.
- No data can be written in the following word devices.  
S (status)  
T (timer), C (counter), R (control) when s= 0 (control word)
- The total number of devices on which data read/write operations can be carried out at a time is as follows:
  - Read: 128 ports (bit devices)  
41 ports (word devices)
  - Write: 128 ports (bit devices)  
1 port (preset and current data of timer, counter, or control)  
41 ports (word devices other than the above)

## 2) Usable station numbers and devices

### Station numbers

- 01 to 31 (Decimal notation)

### Devices

- Bit devices

Device name	Range
Status	Sf: e/b f (file number): 2 [omissible] e (element number): 0 to 255 b (terminal number): 0 to 15
Bit	Bf: e/b f (file number): 3 [omissible] or 9 to 255 e (element number): 0 to 255 b (bit number): 0 to 15 Bf/b f (file number): 3 [omissible] or 9 to 255 b (sum-up bit number): 0 to 4095
Timer	Tf: e. s/b f (file number): 4 [omissible] or 9 to 255 e (element number): 0 to 255 s (word number): 0 to 2 (Note 1) b (bit number): 0 to 15 (Note 2)
Counter	Cf: e. s/b f (file number): 5 [omissible] or 9 to 255 e (element number): 0 to 255 s (word number): 0 to 2 (Note 1) b (bit number): 0 to 15 (Note 3)
Control	Rf: e. s/b f (file number): 6 [omissible] or 9 to 255 e (element number): 0 to 255 s (word number): 0 to 2 (Note 4) b (bit number): 0 to 15 (Note 5)
Integer	Nf: e/b f (file number): 7 [omissible] or 9 to 255 e (element number): 0 to 255 b (bit number): 0 to 15

- Word devices

Device name	Range
Status	Sf: e f (file number): 2 [omissible] e (element number): 0 to 255
Bit	Bf: e f (file number): 3 [omissible] or 9 to 255 e (element number): 0 to 255
Timer	Tf: e. s f (file number): 4 [omissible] or 9 to 255 e (element number): 0 to 255 s (word number): 0 to 2 (Note 1)
Counter	Cf: e. s f (file number): 5 [omissible] or 9 to 255 e (element number): 0 to 255 s (word number): 0 to 2 (Note 1)
Control	Rf: e. s f (file number): 6 [omissible] or 9 to 255 e (element number): 0 to 255 s (word number): 0 to 2 (Note 4)
Integer	Nf: e f (file number): 7 [omissible] or 9 to 255 e (element number): 0 to 255

## Note 1:

In case of 0, “. s” is omissible. In case of 1, “preset value”, “PRE” can be set. In case of 2, “current value”, “ACC” can be set.

## Note 2:

In case of s=0, “EN” can be set if b = 15 “Enable Bit”.

In case of s=0, “TT” can be set if b = 14 “Timing Bit”.

In case of s=0, “DN” can be set if b = 13 “Completed Bit”.

## Note 3:

In case of s=0, “CU” can be set if b = 15 “Up Counter Enable Bit”.

In case of s=0, “CD” can be set if b = 14 “Down Counter Timing Bit”.

In case of s=0, “DN” can be set if b = 13 “Completed Bit”.

In case of s=0, “OV” can be set if b = 12 “Overflow Bit”.

In case of s=0, “UN” can be set if b = 11 “Underflow Bit”.

In case of s=0, “UA” can be set if b = 10 “Latest Value (high-speed counter)”.

## Note 4:

In case of s = 0, “. s” is omissible.

In case of 1 “area size”, “LEN” can be set. In case of 2 “position”, “POS” can be set.

## Note 5:

In case of s=0, “EN” can be set if b = 15 “Enable Bit”.

In case of s=0, “EU” can be set if b = 14 “Enable Bit (unload)”.

In case of s=0, “DN” can be set if b = 13 “Completed Bit”.

In case of s=0, “EM” can be set if b = 12 “Empty Bit”.

In case of s=0, “ER” can be set if b = 11 “Error Bit”.

In case of s=0, “UL” can be set if b = 10 “Out Bit (bit shift)”.

In case of s=0, “IN” can be set if b = 9 “IN Bit”.

In case of s=0, “FD” can be set if b = 8 “Match Bit (sequencer comparison)”.

## 3) OIP connection

RS-232C

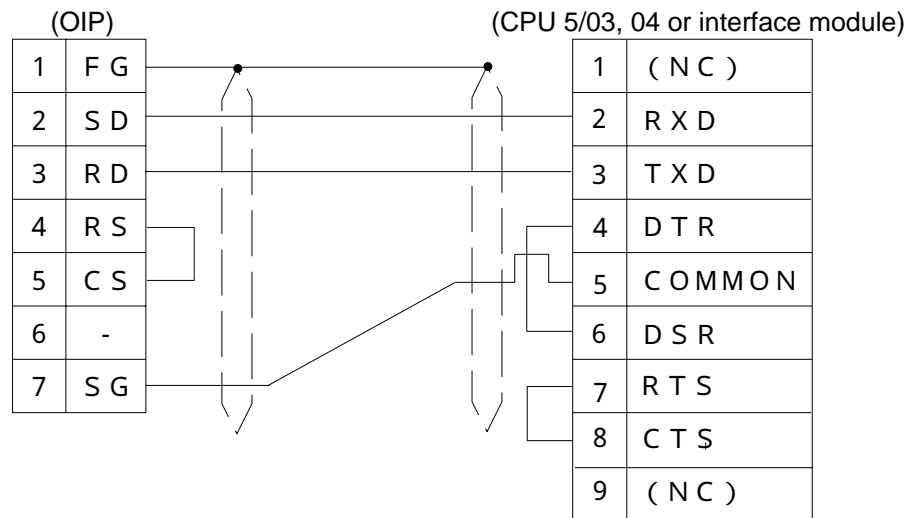

## 16. Multipanel Unit

### 16.1 KDP21NU-1

The use of the multipanel unit (KDP21NU-1) allows to connect up to 8 OIPs to one PLC. For how to use it, refer to the multipanel unit instruction manual. For connectable PLC types and link units, refer to Section 2, "List of Connectable PLC Types" of Chapter II.

#### 1) OIP connection

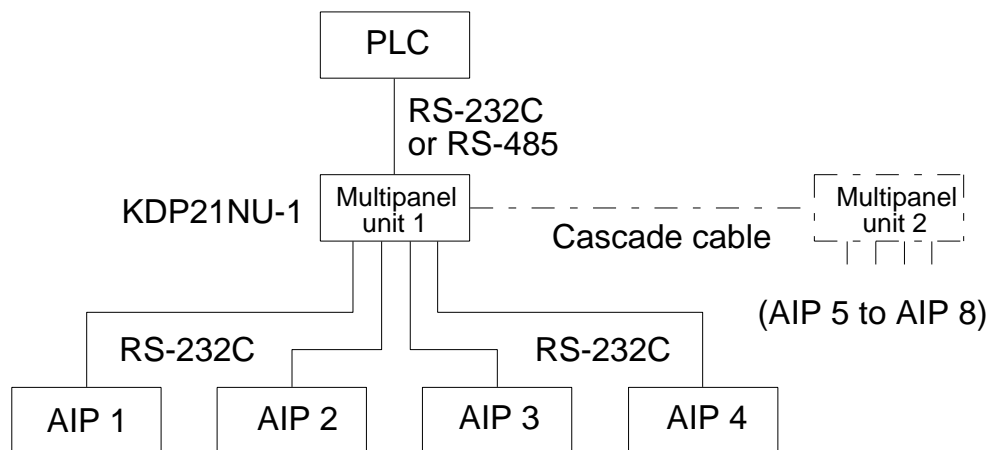



---

# APPENDIX

## LINK UNIT SETTING

This section describes the setting items of PLCs and link units of various manufacturers for reference. For further details, refer to the manual of the suppliers' PLC or link unit.





# 1. Setting the Computer Link Unit (AJ71UC24) of Mitsubishi

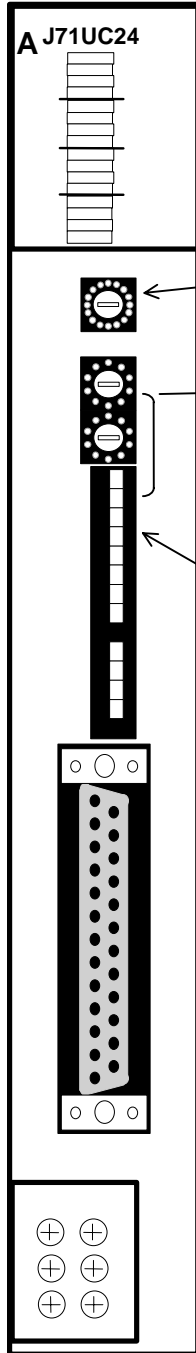

Refer to the following to set the computer link unit.

- Channel setting
- Station number setting
- Communication format setting

For RS-232C, set "4" (format 4 protocol mode).  
For RS-422/RS-422/RS-485, set "8" (format 4 protocol mode).

Station No., set the number within 00 to 31.  
The standard value is "00".

Setting Switch	Setting Item	Setting Switch Status		Remark																					
		ON	OFF																						
SW11	Sets the main channel.	RS-422/RS-422/ RS-485	RS-232C	The customer must select these items.																					
SW12	Sets data bits.	8 bits	7 bits																						
SW13	Sets a transfer rate.	<table border="1"> <tr> <td>1200</td> <td>2400</td> <td>4800</td> <td>9600</td> <td>19200</td> </tr> <tr> <td>OFF</td> <td>ON</td> <td>OFF</td> <td>ON</td> <td>OFF</td> </tr> <tr> <td>ON</td> <td>ON</td> <td>OFF</td> <td>OFF</td> <td>ON</td> </tr> <tr> <td>OFF</td> <td>OFF</td> <td>ON</td> <td>ON</td> <td>ON</td> </tr> </table>			1200	2400	4800	9600	19200	OFF	ON	OFF	ON	OFF	ON	ON	OFF	OFF	ON	OFF	OFF	ON	ON	ON	
1200		2400	4800		9600	19200																			
OFF		ON	OFF		ON	OFF																			
ON		ON	OFF		OFF	ON																			
OFF	OFF	ON	ON		ON																				
SW14																									
SW15																									
SW16	Presence of parity bit	ON	None																						
SW17	Parity type	Even	Odd																						
SW18	Sets stop bit(s).	2 bits	1 bit																						
SW21	Presence of sum check	ON	/	Be sure to set ON for these items.																					
SW22	RUN writing Yes/No	Yes																							
SW23	Computer link	Computer link																							
SW24	Not used																								

Note: Set the transfer rate as high as possible to speed up screen display.

## 2. Setting the Computer Link Unit (AJ71C24) of Mitsubishi

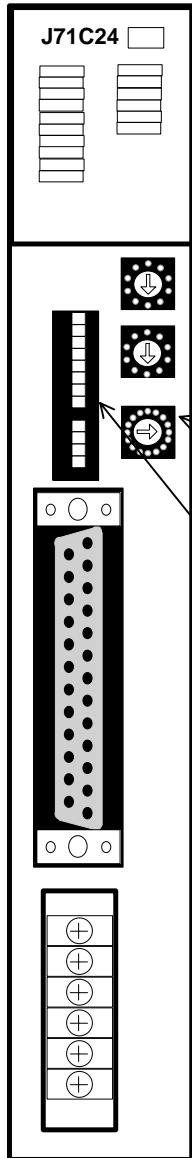

Refer to the following to set the computer link unit.  
 Channel setting  
 Station number setting  
 Communication format setting

Station number      Set the number within 00 to 31.  
 The standard value is "00".

For RS-232C, set "4" (format 4 protocol mode).  
 For RS-422, set "8" (format 4 protocol mode).

Setting Switch	Setting Item	Setting Switch Status		Remark																				
		ON	OFF																					
SW11	Sets the main channel.	RS-422/	RS-232C	The customer must select these items.																				
SW12	Sets data bits.	8 bits	7 bits																					
SW13 SW14 SW15	Sets a transfer rate.	<table border="1"> <tr> <td>1200</td> <td>2400</td> <td>4800</td> <td>9600</td> <td>19200</td> </tr> <tr> <td>OFF</td> <td>ON</td> <td>OFF</td> <td>ON</td> <td>OFF</td> </tr> <tr> <td>ON</td> <td>ON</td> <td>OFF</td> <td>OFF</td> <td>ON</td> </tr> <tr> <td>OFF</td> <td>OFF</td> <td>ON</td> <td>ON</td> <td>ON</td> </tr> </table>			1200	2400	4800	9600	19200	OFF	ON	OFF	ON	OFF	ON	ON	OFF	OFF	ON	OFF	OFF	ON	ON	ON
1200	2400	4800	9600		19200																			
OFF	ON	OFF	ON		OFF																			
ON	ON	OFF	OFF		ON																			
OFF	OFF	ON	ON		ON																			
SW16	Presence of parity bit	ON	None																					
SW17	Parity type	Even	Odd																					
SW18	Sets stop bit(s).	2 bits	1 bit																					
SW21	Presence of sum check	ON	/																					
SW22	RUN writing Yes/No	Yes																						
SW23	Transmitter terminal resistor	Provided																						
SW24	Receiver terminal resistor	Provided																						
				Be sure to set ON for these items.																				

Note: Set the transfer rate as high as possible to speed up screen display.

### 3. Setting the C200H-LK101/LK201/LK202 of Omron

Set the host communication unit as shown below.

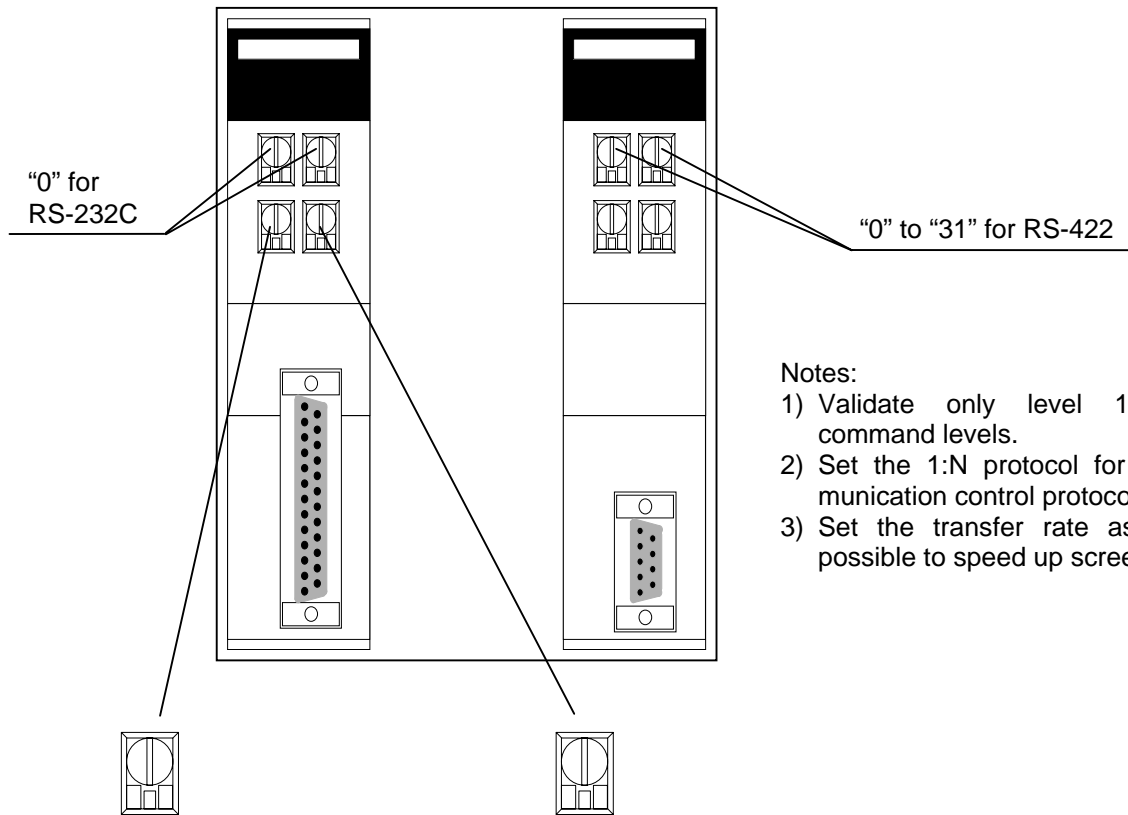

**Notes:**

- 1) Validate only level 1 of the command levels.
- 2) Set the 1:N protocol for the communication control protocol.
- 3) Set the transfer rate as high as possible to speed up screen display.

Transfer Rate	SW3
19200bps	6
9600	5
4800	4
2400	3
1200	2

SW4	Command Level	Parity	Transmission Code
2	Levels 1, 2, 3 valid	Even	ASCII 7-bit
6		Odd	Stop bit length: 2
A		Even	JIS 8-bit
E		Odd	Stop bit length: 1

• Setting the switches on the rear panel

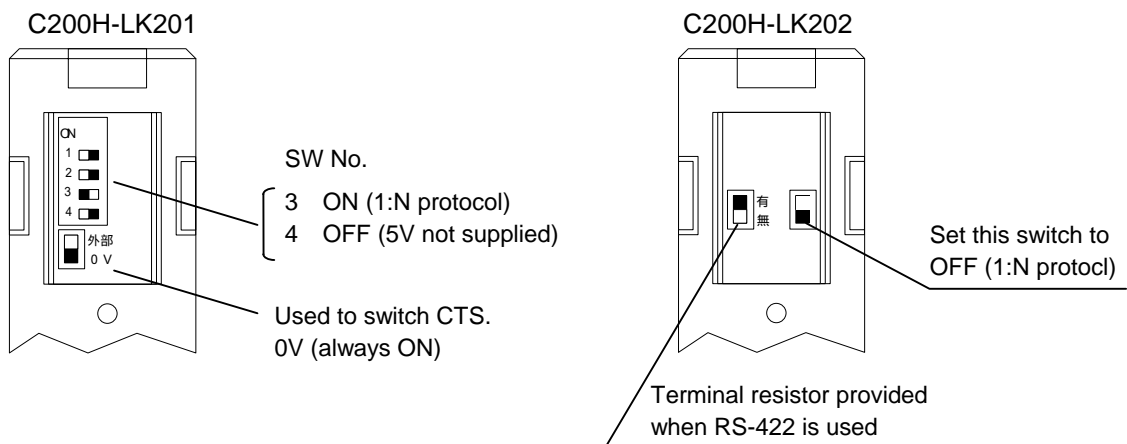

SW No.  
 3 ON (1:N protocol)  
 4 OFF (5V not supplied)

Used to switch CTS.  
 0V (always ON)

Set this switch to  
 OFF (1:N protocol)

Terminal resistor provided  
 when RS-422 is used

## 4. Setting C500-LK101/LK201-V1 of Omron

Set the host communication unit as shown below.

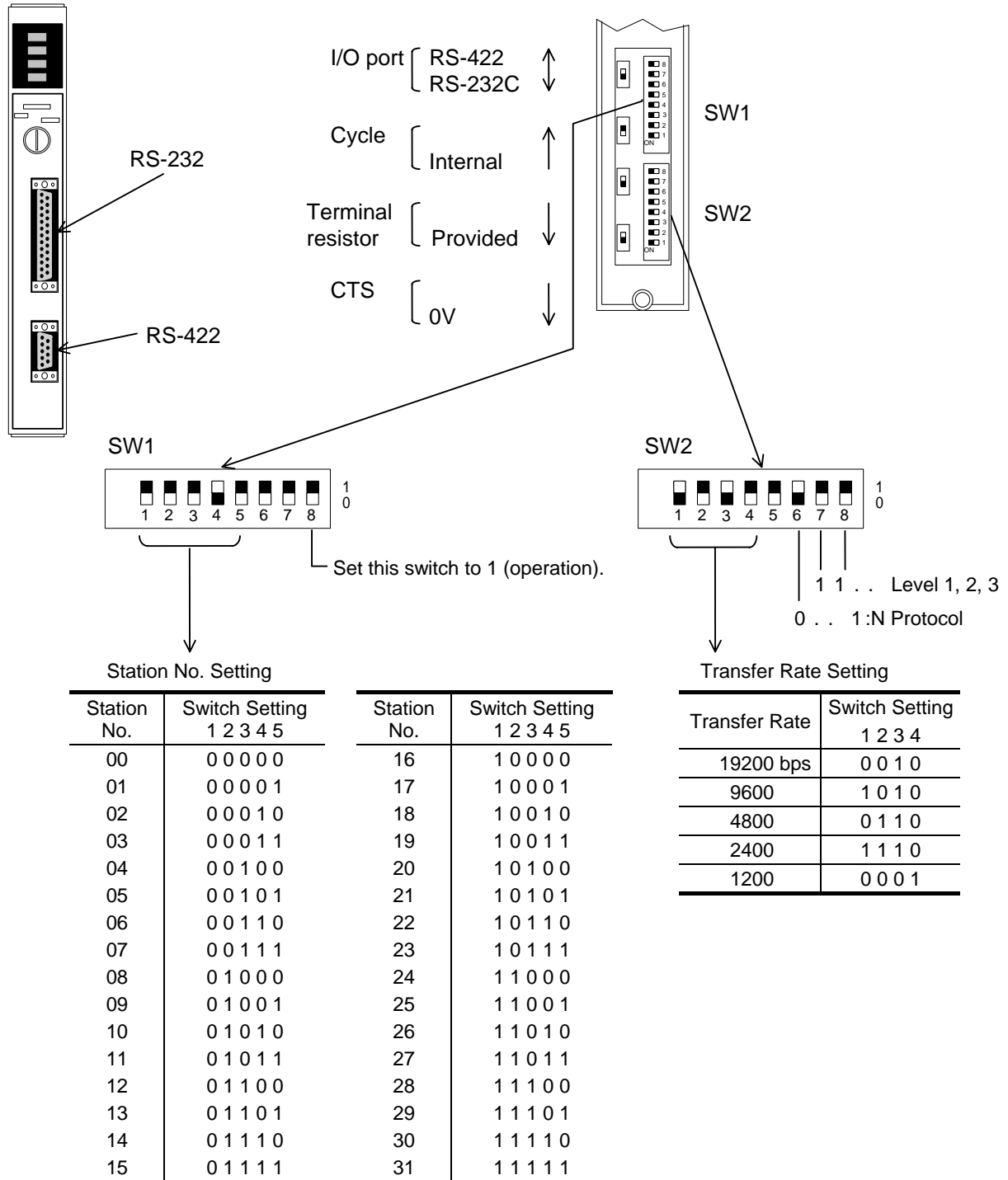

### Notes:

- 1) Validate of the command 1, 2, and 3 levels.
- 2) Set the 1:N protocol for the communication control protocol.
- 3) Set OIP as shown below.  
 Parity type: Even  
 Date length: 7 bits  
 Stop bit length: 2 bits

## 5. Setting C500-LK203 of Omron

Set the host communication unit as shown below.

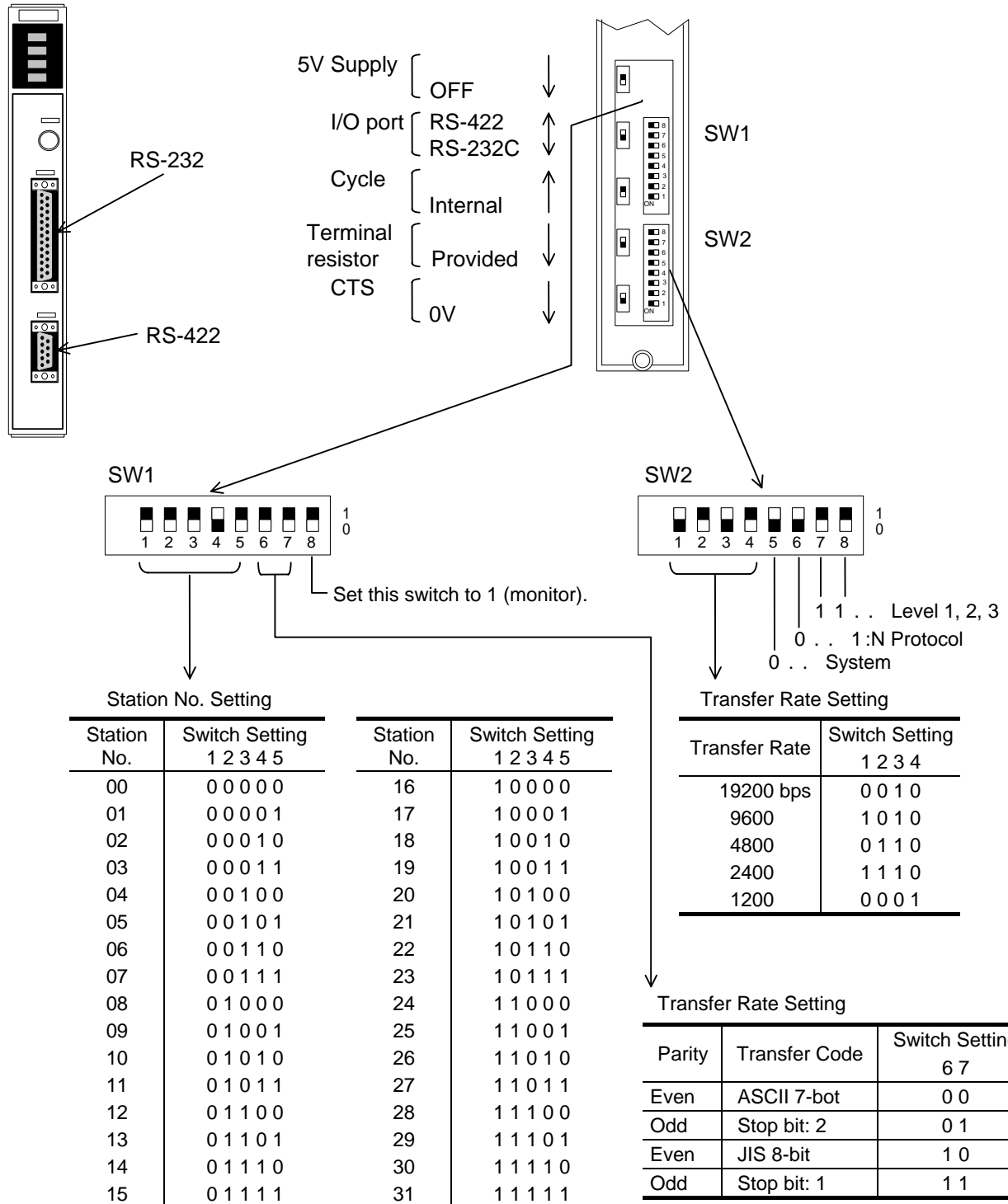

### Notes:

- 1) Validate the command 1, 2, and 3 levels.
- 2) Set the 1:N protocol for the communication control protocol.
- 3) Set the transfer rate as high as possible to speed up screen display.  
The screen display speed will be increased.

## 6. Setting CV500-LK201 of Omron

Set the host communication unit as shown below.

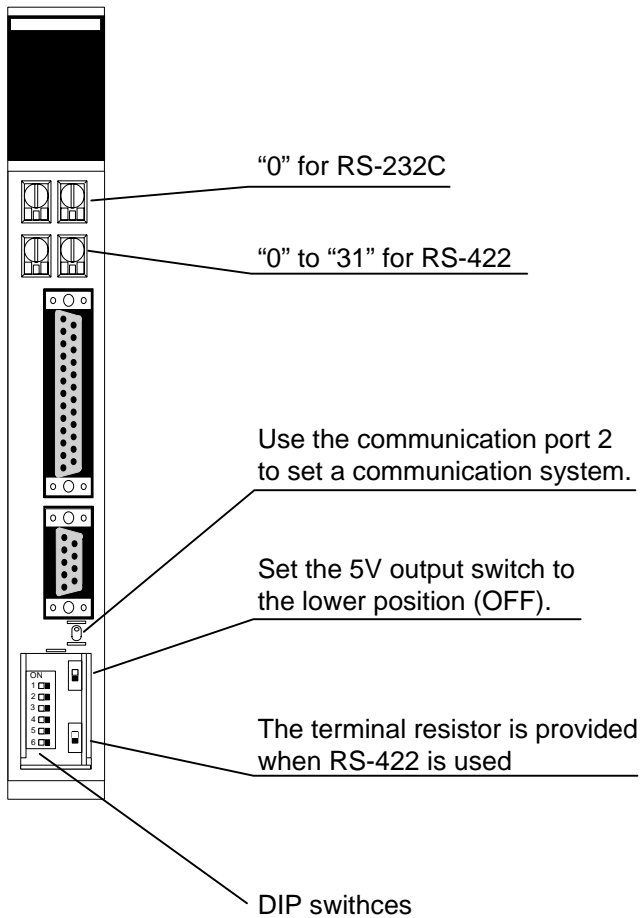

Note: Add a terminal resistor to the cable between the host communication unit and OIP.

SW No.	Function	Set Value	
1	Used to set communication conditions.	ON	Transmission speed: 2400 bps Stop bit length: 1 bit Parity type: Even Data length: 7 bits
		OFF	Transmission speed: 9600 bps Stop bit length: 1 bit Parity type: Even Data length: 7 bits
2	Used to change over CTS (communication port 1).	ON	Keep CTS signal turned ON.
3	Used to change over CTS (communication port 2).	ON	Not needed for RS-422.
4	Reserved	OFF	
5	Used for loopback communication tests.	OFF	
6	Used to specify a test port.	OFF	

Note: Set the transfer rate as high as possible to speed up screen display. The screen display speed will be increased.

## 7. Setting CQM1-CPU21 of Omron

This product incorporates a host communication port in its CPU module.

The DIP switches and registers are used to set the link unit.

When the DIP SW5 is ON, the internal setting is fixed. When the DIP SW5 is OFF, channel number set values are assumed.

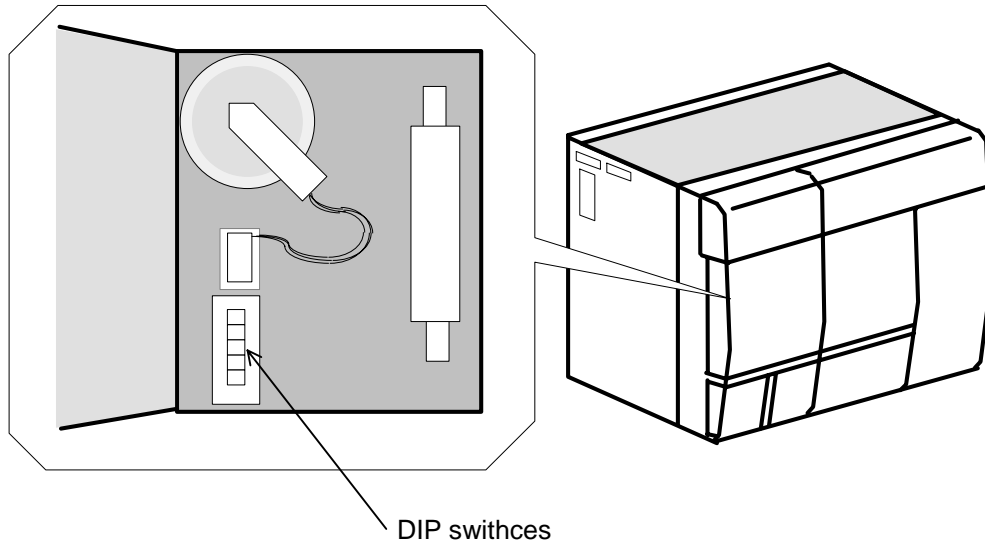

1. When DIP SW5 is "ON";  
Be sure to set OIP as shown below.
2. When DIP SW5 is "OFF";  
Set the port according to the channel number (DM6645 or DM6646) set value.

### Setting of DM6645

Bits 15 to 12	0:High-order link	1:RS232 non-procedure	2:Slave station in 1-to-1 link
Bits 11 to 8	0:LR00 to 63CH	1:LR00 to 31CH	2:LR00 to 15CH
Bits 7 to 0	00:Standard setting Data length:7, Parity:Even Stop bits:2, Transmission rate:9600bps		01:According to DM6646 setting

: Fix it to this setting.

### Setting of DM6646

#### Transfer Format for 15 down to 8 bits

	Data Length	Stop Bit	Parity Type
00	7	1	Even
01	7	1	Odd
02	7	1	None
03	7	2	Even
04	7	2	Odd
05	7	2	None
06	8	1	Even
07	8	1	Odd
08	8	1	None
09	8	2	Even
10	8	2	Odd
11	8	2	None

#### Transfer Rate for 7 down to 0 bit

Set Value	Transfer Rate
00	1200bps
01	2400bps
02	4800bps
03	9600bps
04	19200bps



## 8. Setting COMM Module (COMM-H/COMM-2H) of Hitachi

LED ON/OFF

Station No. Setting

GCSGP3 Setting

- Hitachi (H) RS-232C···"0"
- Hitachi (H CPU) RS-422···"2" or "4"
- Hitachi (H CPU) RS-232C···"2"

Switch No.	Item	ON		OFF		
1	Data bit length	8			7	
2	Transmission speed (bps)	1200	2400	4800	9600	19200
3		OFF	ON	OFF	ON	OFF
4		ON	ON	OFF	OFF	ON
4		OFF	OFF	ON	ON	ON
5	Parity	ON			OFF	
6	Parity type	Even			Odd	
7	Stop bit length	2			1	
8	Sum check	ON				

Set the PLC network address as follows.

- L (Loop No.) = Fixed to FF (H)
- U (Unit No.) = Fixed to FF (H)
- M (Module No.) = Fixed to 00 (H)
- P (Port No.) = Fixed to 00 (H)

Memory is occupied/released automatically for writing from OIP.

## 9. Setting ZW-10CM of Sharp

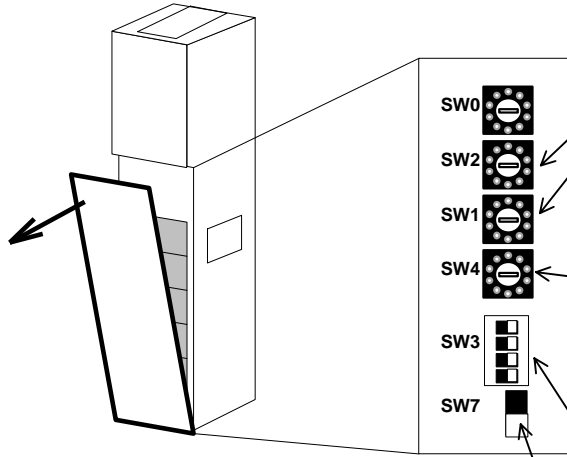

### Station No. Setting

Set the station No. to any of the following (in octal), "01" to "07", "11" to "17", "21" to "27", "31" to "37". (SW2 is high-order, while SW1 is low-order.)

SW4 Setting	Transfer Rate (bps)
0	19200
1	9600
2	4800
3	2400
4	1200

SW3 Setting	Operation	
	ON	OFF
1		Invalid
2	4-wire type	
3		Invalid
4	Parity: Even	Parity: Odd

### Terminal Resistor Setting

SW7 Setting	Operation	
	ON	OFF
	Inserted	None

Set OIP as shown below.

Data length: 7 bits

Parity: ON

Stop bit length: 2 bits

## 10. Setting the Communication Module (IOP, COMM) of Yasukawa

Port No. Settings

S <sub>1</sub>	S <sub>2</sub>	Module No.	Port No.	
			Odd Port	Even Port
OFF	OFF	1	1	2
ON	OFF	2	3	4
OFF	ON	3	5	6
ON	ON	4	7	8

**Transmission Mode**  
Set S<sub>3</sub> to S<sub>6</sub> to OFF.

**Transmission Parameters**

The transmission parameters are set on the register access panel.  
Use six-digit unique numbers for setting of the communication parameters.

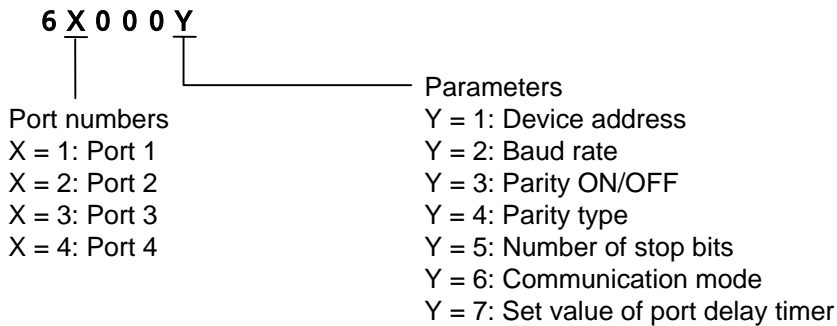

1. Device address  
Select a device address between 1 and 247.
2. Baud rate  
Select 1200, 2400, 4800, 9600 or 19200.
3. Parity ON/OFF  
PARITY ON or NO PARITY
4. Parity type  
EVEN or ODD
5. Number of stop bits  
1 STOP (1 stop bit) or 2 STOP (2 stop bits)
6. Communication mode  
Select RTU or ASCII, which should be identical to that of "Yasukawa (RTU)" or "Yasukawa (ASCII)" in "Environmental Setting" of GCSGP3.  
The data bit length is 7 when "ASCII" is selected.  
The data bit length is 7 when "RTU" is selected.

## 11. Setting the Personal Computer Link Module (F3LC01-1N) of Yokogawa

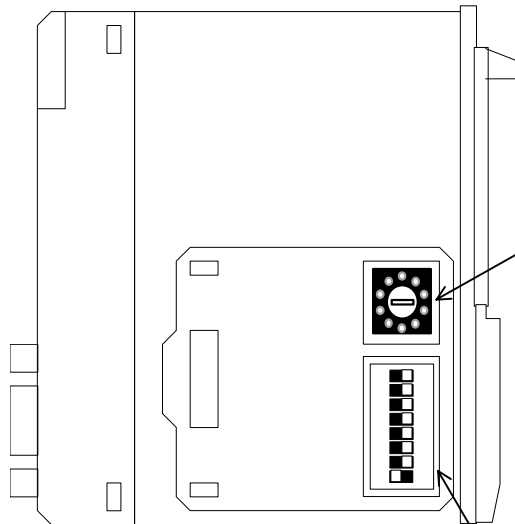

SW4 Setting	Transfer Rate (bps)
2	1200
3	2400
4	4800
5	9600
6	19200

Switch No.	Item		
		ON	OFF
1	Data bit length	8	7
2	Parity	ON	OFF
3	Parity type	Even	Odd
4	Stop bit length	2	1
5	Sum check	ON	OFF
6	Terminal character specification	ON	OFF
7	Protection function	ON	OFF
8			

: Fix it to this setting.

Note 1: The station No. is fixed to "01".

Note 2: If you select [Yokogawa (CPU No. variable)] or [Yokogawa (CPU No. variable) (High-speed communication)] from the connection devices of the "Project Property" on Screen Creator 5 for Sum-check, set [No], or if you select any of the units other than the above, set [Yes].

## 12. Setting the Personal Computer Link Module (LC02-1N) of Yokogawa

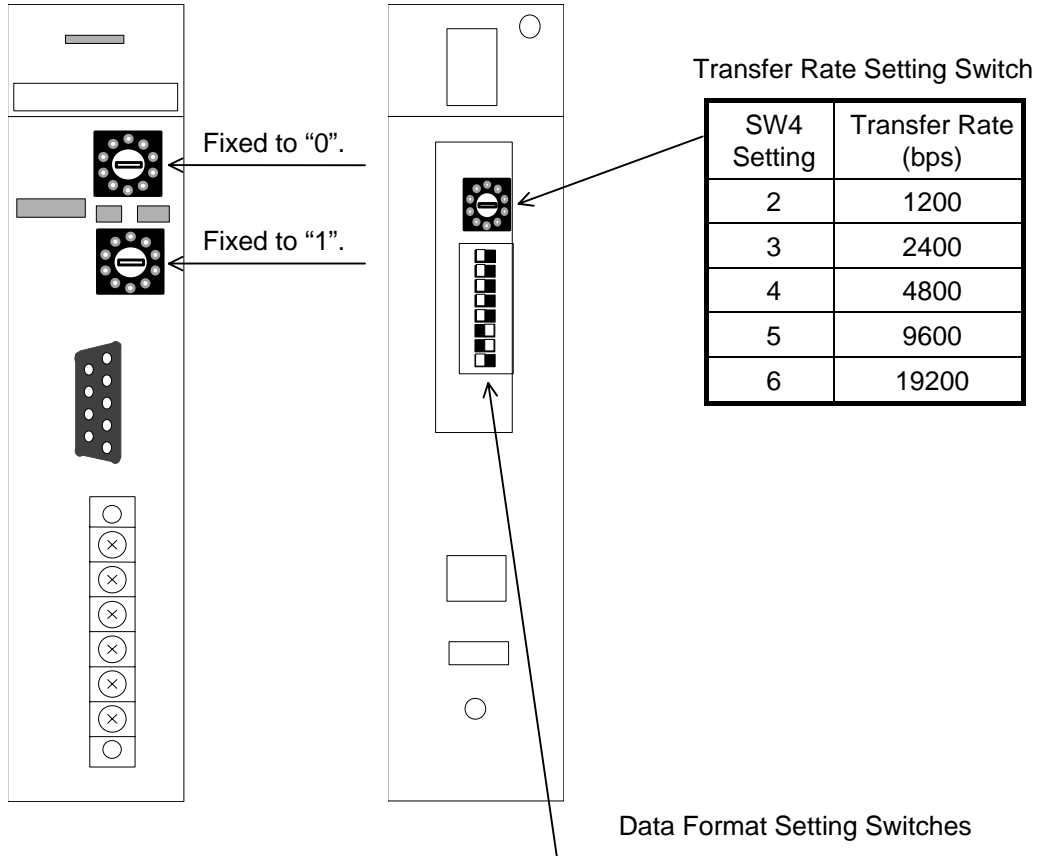

Switch No.	Item		
		ON	OFF
1	Data bit length	8	7
2	Parity	ON	OFF
3	Parity type	Even	Odd
4	Stop bit length	2	1
5	Sum check	ON	OFF
6	Terminal character specification	ON	OFF
7	Protection function	ON	OFF
8			

 : Fix it to this setting.

Note 1: The station No. is fixed to "01".

Note 2: If you select [Yokogawa (CPU No. variable)] or [Yokogawa (CPU No. variable) (High-speed communication)] from the connection devices of the "Project Property" on Screen Creator 5 for Sum-check, set [No], or if you select any of the units other than the above, set [Yes].

### 13. Setting the Computer Communication Unit (CCU) of Matsushita

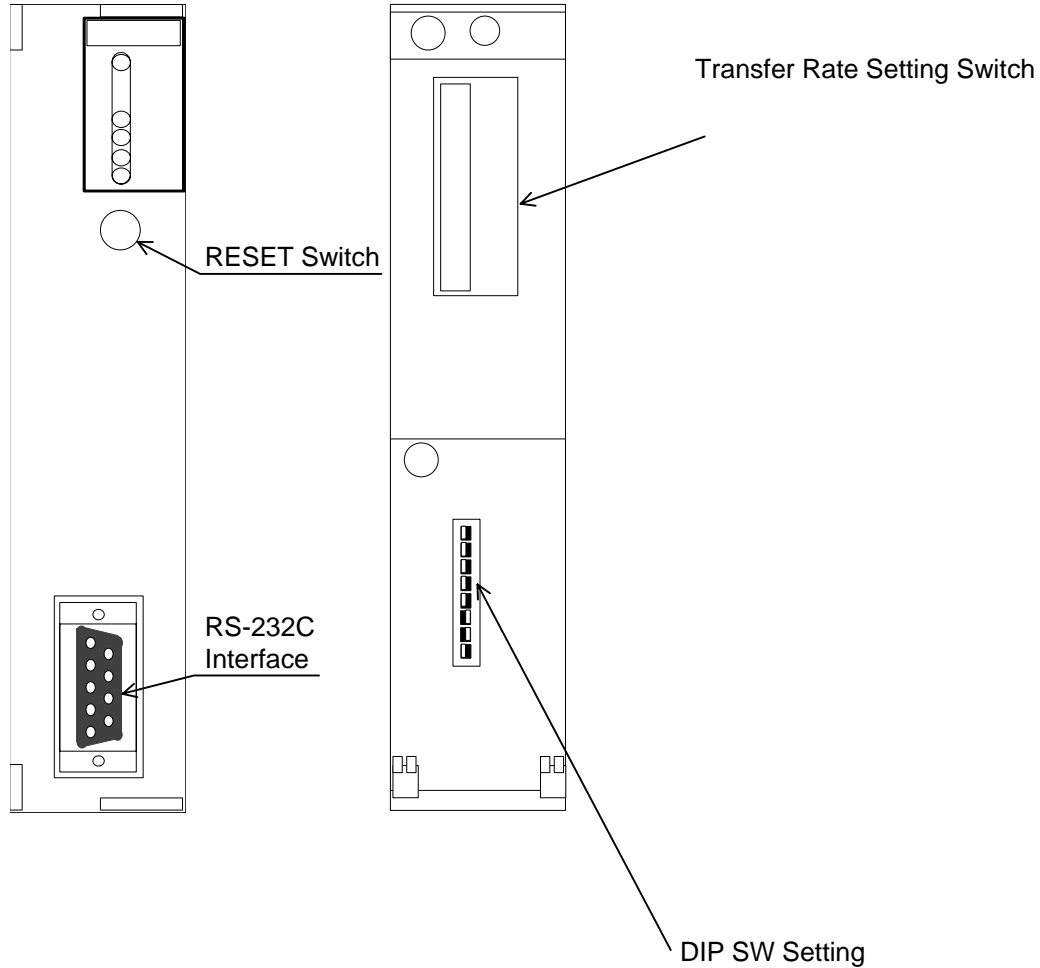

Switch No.	Item	ON					OFF				
		1200	2400	4800	9600	19200					
1	Transmission speed (bps)	ON	OFF	ON	OFF	ON					
2		OFF	OFF	ON	ON	OFF					
3		ON	ON	OFF	OFF	OFF					
4	Data bit length	8					7				
5	Parity	ON					OFF				
6	Parity type	Even					Odd				
7	Stop bit lengths	2					1				
8	Control signal	CS and CD valid					CS and CD invalid				

: Fix it to this setting.

---

## 14. Setting the Link Unit (T Series) of Toshiba

### (1) Setting transmission parameters

Set the transmission parameters needed to link the subject personal computer. The same parameters must be set for both personal computer and OIP.

- Setting transmission parameters of the personal computer  
Set the transmission parameters for linking a personal computer.  
The transmission parameters can be set from the T series programmer/T-PDS.

Connect the personal computer to the programmer (directly) and start up both.

When the programmer is started up, select menus in the following order.

↓  
S: System control information (main menu title screen)

↓  
I: System information (sub-menu system control information)

The system parameter setting screen appears.

Press [F2] (Page Change) to open the 2nd page and set each necessary item of "7. Computer Linking".

	Setting Range	Initial Value
Station No.	1 to 32	1
Baud rate	1200/2400/4800/9600/19200bps	9600
Parity	None/Even/Odd	Odd
Data bit length	7/8Bit	8Bit
Stop bit length	1 bit/2 bits	1Bit

Press [F1] (SET) to set each necessary item. After this, press [F3] (REGISTER) to register the set values.

## 15. Setting the CPU Unit (EX100) of Toshiba

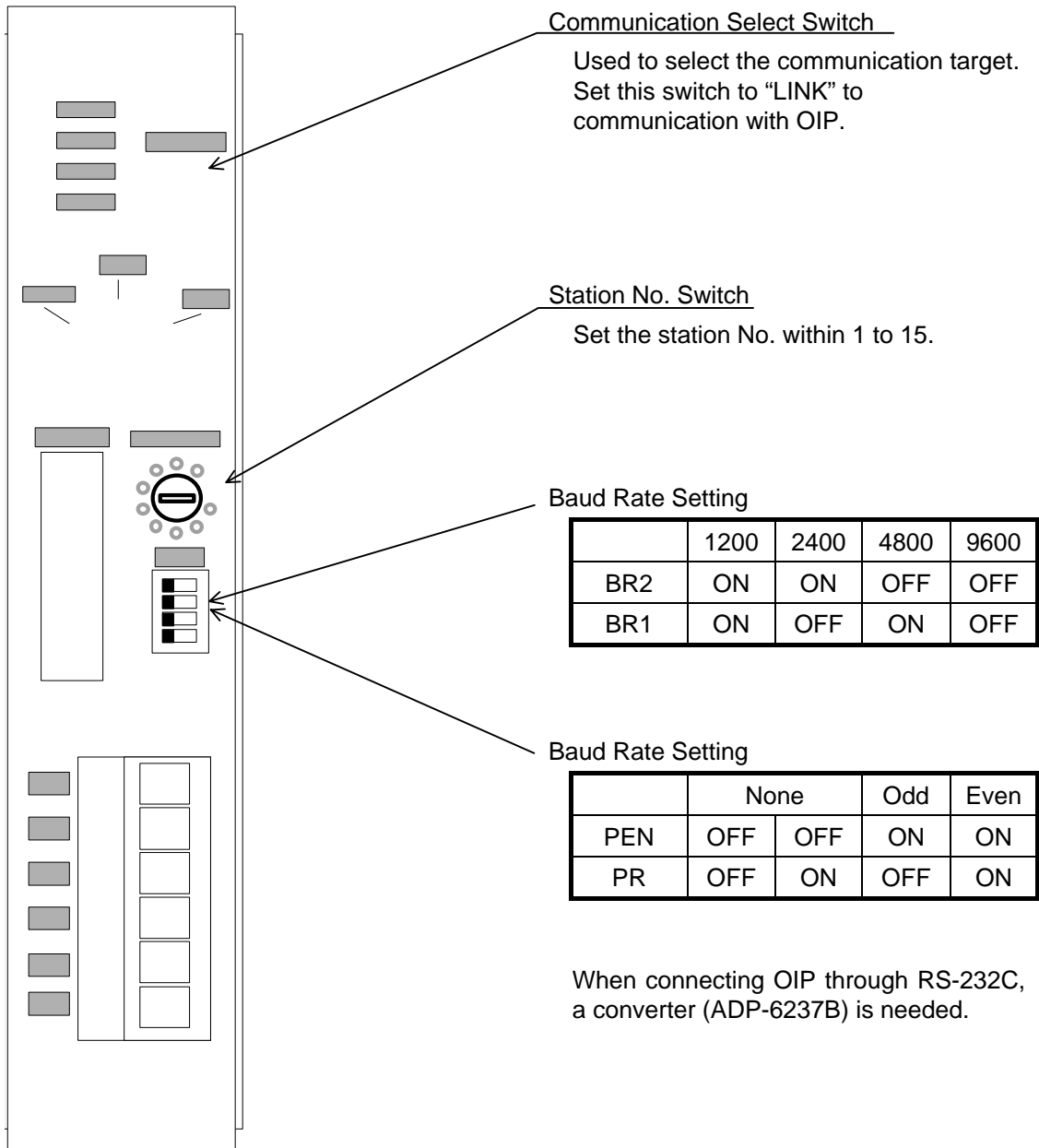



---

## **CHAPTER III**

# **COMMUNICATION WITH A HOST COMPUTER (Host Command Communication)**

## 1. OUTLINE

---

This system can use any of the command communication method, memory link communication method (memory-to-memory communication method), and non procedure communication method to communicate with the host computer.

The command communication method uses a dedicated protocol. This method displays data according to the commands from the host computer and send switch information and other data to the host computer. In this case, you must create the software to send/receive commands according to the dedicated protocol on the host computer side.

Host parts are prepared in standard parts libraries. Refer to them when creating screens.

For the memory link system, refer to Chapter V, "Communication with A Host Computer (Memory Link Communication)". For the non procedure system, refer to Chapter IV, "Communication with A Host Computer (Non Procedure Communication)".

OIP



- Response command

Name	Description	Required or not	Data length	Range	Default
Start code	Starting code of the packet	○/x	1 byte	01 - 7FH	02H
Sta. No.	Station number of the OIP	○/x	2 bytes	00 - FF (ASCII code)	Not used
Destination name	Screen name and part name	○	–	–	–
T1	Terminator of the destination name	○	1 byte	01 - 7FH	01H
Command	Command	○	1 byte	39H (fixed)	–
Data	Outgoing numeric/character string data to the destination	○		–	–
T2	Terminator of the outgoing data to the destination	○	1 byte	01 - 7FH	04H
End code	Ending code of the outgoing data	○	1 byte	01 - 7FH	03H
SUM	Sum check A value expressed by a character code of 2 bytes by adding in 8 bits the section from the start code to the end code and then taking the 2's complement for the last 8 bits of the result.	○/x	2 bytes	–	Yes
Terminator 1	Terminator 1 of the packet	○	1 byte	01 - 7FH	0DH
Terminator 2	Terminator 2 of the packet	○/x	1 byte	01 - 7FH	0AH
ACK	Normal response	○	1 byte	01 - 7FH	06H
NAK	Abnormal response	○	1 byte	00 - 7FH	15H

Notes: 1. The symbol o under “Required or not” in the table above indicates that a value must be set in the item.

Likewise, the symbol ○/x indicates that depending on the particular setting of the communication format, it can be selected whether the item is to be used.

2. If the start code or terminator 2 are not to be used, set “00H” in both items.

## 2.3 Data Structures

The structures of outgoing data must obey the following rules:

- Different data must be set in all data items, such as the codes and the terminators. Also, the data block within the packet must not contain the same value as that of any of those data items.
- The station number, the destination name, the data, and the SUM must be sent in the ASCII text format. Numeric data must therefore be converted into the ASCII text format beforehand.
- Multiple pieces of information can be included in one set of data to be sent. In that case, data items must be separated by the comma [,].



**The comma itself cannot be sent as data.**



### 3. SETTING THE TYPE OF PROTOCOL

---

To connect the OIP to a host computer, the type of protocol must be set, as with a PLC, during creation of a screen on GCSGP3. If a screen for operating peripheral units is created without the protocol type being set, an error will occur during creation of the data to be downloaded.

The setting procedure is described below. For further details, refer to Section 3, "Setting a PLC Manufacturer Names and Model Numbers" of Chapter III.

Select "Project Properties" on the "Project" menu.

Click on the "Connection Equipment" tag in the Properties window of the project.

Click on the " " mark of "Host Computer". A list is displayed. Select "Host Command Communication".

---

## 4. SETTING A COMMUNICATION FORMAT

---

To use the special protocol, the format of the communication packet must be set.  
Set the format using the following procedure:

Select [System Setup] from the menu of the system mode.

When the system-setting menu is displayed, select [Setting of Communication Format with Host].  
This displays the following screen:

Touch the display frame of the item to be set. This opens a ten-key pad (data keypad). Input a numeric value.

The message "ERROR Occurred" will be displayed if the input value is out of the required range.  
Re-set a value in that case.

After the value has been set, touch [OK] to terminate setting.

## 5. SETTING COMMUNICATION PARAMETERS

---

Set the parameters for the communication port that you are going to use. Refer to Section I, "GENERAL DESCRIPTION", for further details of setting.

Connected Device  
Select [Host].

Communication parameters

Set other parameters according to the particular communication specifications of the host computer. Defaults are as follows:

Baud Rate = 9600  
Parity = EVEN  
Stop Bits = 2  
Data Length = 8  
Retry Count = 1  
Time Out = 3 (sec)  
Xon/Xoff = No  
Check-Sum = Yes

Host communication formats

Start Code = 2  
Machine ID Number = Not used  
End of Sendee Code = 1  
End of Data Code = 4  
End Code = 3  
Terminator Code 1 = D  
Terminator Code 2 = A  
Check-Sum (Yes/No) = Yes  
ACK Code = 6  
NAK Code = 15



## 6. CABLE CONNECTION

---

RS-232C

[OIP]

RS-422/RS-485

[OIP]

[OIP]

[OIP]



Although an RS-232C/RS-422/RS-485 converter can be used to execute 1:N communication, always start this only from the master (host). Data will collide if 1 : N connection is started from the slave (OIP) at the same time.



---

## **CHAPTER IV**

# **COMMUNICATION WITH A HOST COMPUTER (Non Procedure Communication)**

## 1. OUTLINE

---

The non procedure communication method is used to communicate with devices other than the devices (e.g., each maker's PLC, host computer, etc.) for which OIP supports the necessary communication protocol.

Using this communication method, communications can be made with modems, IC card readers, and other devices having their own protocols (temperature regulators, various types of controllers, etc.) through RS-232C or RS-422/RS-485.

For such the communications, the communication protocol must be described with K-Basic, however.

## 2. SYSTEM SETTING

---

If the non procedure communication method is to be used, set the object system from your OIP as shown below.

Select "System Setup" from the system mode menu and select the object channel (any of RS-232C-1, RS-232C-2, and RS-422/RS-485).

Set "Not Use" for communication type.

Set the communication speed, parity, stop bit length, and data length parameters according to the object remote device.

Only the time-out value in the detailed setting items is effective. If no data is received even though the time-out period has elapsed, a time-out error occurs. If 0.0 is set, the time-out period becomes infinite and no time-out error occurs.

No detailed setting is required. If set, it is ignored.

It is also no need to set the communication format for the host computer. If set, it is ignored.

Note: If this non procedure communication method is used, the communication items to be set on the "Project Property" of Screen Creator 5 are all omissible.

## 3. HOW TO DESCRIBE A PROTOCOL WITH K-BASIC

---

K-Basic must be used to describe the communication protocol for the communications with remote devices using the non procedure communication method. The following commands are used in that case.

OPENSIO	Opens the serial port.
SETSIO	Sets how to receive data.
WRITESIO	Sends data.
WRITESIOB	Sends data (in binary mode).
FLUSH	Clears the receive buffer.
CLOSESIO	Ends the communication.

For details, refer to Vol. 6 "Screen Creator 5, K-Basic Program Description".

Non-procedure communication parts are available as the standard parts. For details, refer to "Non-procedure communication parts" in the section "Special parts" in the "Screen Creator 5 Standard Parts Catalog".

### 3.1 Notes on Describing with K-Basic

You should keep the following in mind when using the non procedure communication method.



- Execute the **OPENSIO** and **SETSIO** commands for the part that receives data beforehand.
- The **OPENSIO** command cannot be executed for plural parts in the same channel concurrently.
- Use a character string variable in K-Basic as a buffer to receive data. This variable must be global or static type one.
- Never fail to execute the **FLUSH** command after data is received. Otherwise, the receive buffer will become full.
- The **WRITESIO** and **WRITESIOB** commands can be used to send data. Those commands allow data to be sent out from any parts. In that case also, if a channel is not opened with the "OPENSIO" command, an error will occur.
- **WRITEIO** or **WRITESIOB** does not output data immediately through the serial port. It stores data in the buffer in the OIP once. To clear the transmission buffer, use **IOCTL**.

## 3.2 Programing Examples

This section will explain how to program for reading/writing data from/in a data recording device that uses the following communication protocol. The examples will be useful for actual programming.

[Communication Protocol Specifications]

Reading of data

Command

RD:	READ command (2 bytes)
XXXX:	Read start address (4 bytes)
YY:	Read byte count (2 bytes)
ODH:	End code (1 byte)

Response

data:	Read data (read byte count x 2 bytes)
ODH:	End code (1 byte)

Writing of data

Command

WR:	WRITE command (2 bytes)
XXXX:	Write start address (4 bytes)
YY:	Write byte count (2 bytes)
data:	Write data (write byte count x 2 bytes)
ODH:	End code (1 byte)

Response

OK:	Response code (2 bytes)
ODH:	End code (1 byte)

## [Programming for Reading Data]

The following K-Basic programming example is for reading data from the object data recording device and displaying it when a switch is pressed.

```

conf
  static rcvbuf$ * 200          ' Allocate a receive buffer.
  static sndbuf$ * 200        ' Allocate a send buffer.
end conf
evnt
  input type%, id@            ' Read the event type.
  if type% = 3 then          ' If an alternate switch is pressed,
    opensio 1, 1, rcvbuf$    ' Open the CH1 port in the text mode.
    setsio 1, &h0d           ' Set a terminator code for receiving data.
    sndbuf$ = "RD10001" + chr$(&Hd) ' Create a packet for reading one byte from address 1000.
    writesio 1, sndbuf$      ' Send the created packet.
  else if type@ = 7 then    ' If data is received,
    input port%, status%, nums% ' Read the port number, status, and received data count.
    if status% = 0 then    ' If no error is detected,
      moji$ = left (rcvbuf$, 2) ' Read only the data in address 1000.
      strdsp.. STR000, moji$ ' Display the read data.
    endif
    closesio 1             ' Close CH1.
  end if
end evnt

```

## [Programming for Writing Data]

The following K-Basic programming example is to write data in a data recording device when the object switch is pressed.

```

conf
  static rcvbuf$ * 200          ' Allocate a receive buffer.
  static sndbuf$ * 200        ' Allocate a send buffer.
end conf
evnt
  input type%, id@            ' Read the event type.
  if type% = 3 then          ' If an alternate switch is pressed,
    opensio 1, 1, rcvbuf$    ' Open the CH1 port in the text mode.
    setsio 1, &h0d           ' Set a terminator code for receiving data.
    writedata$ = "50"        ' Set write data.
    sndbuf$ = "WR10001" + writedata$ ' Create a packet for writing one byte data in address 1000.
      + chr$(&Hd)
    writesio 1, sndbuf$      ' Send the created packet.
  else if type@ = 7 then    ' When data is received,
    input port%, status%, nums% ' Read the port number, status, and received data count.
    if status% = 0 then    ' When no error is detected,
      moji$ = left (rcvbuf$, 2) ' Read only the response status.
      if moji$ = "OK" then    ' If writing is successful,
        strdsp.. STR000, moji$ ' Display the received data.
      endif
    endif
    closesio 1             ' Close CH1.
  end if
end event

```

## 4. ERROR PROCESSINGS

---

If an error is detected while data is received, the INPUT command can be used in K-Basic to read the error status.

If an error (receive buffer full) is detected, it is regarded that the receiving of data has been completed with the data received so far.

In this case, the error-detected received data is sent to the part that has opened the serial port.



---

# **CHAPTER V**

## **COMMUNICATION WITH A HOST COMPUTER (Memory Link Communication)**

## 1. OUTLINE

Memory link communication (also called Memory-to-Memory communication) is one of the schemes of communication between a host computer (in the remainder of this manual, simply referred to as the host) and the advanced intelligent panel (OIP).

During memory link communication, the OIP and the host exchange data through the storage areas of the OIP. These storage areas are called "memory tables".

In the "memory link communication method" of this system, Type I or Type II protocols can be selected according to the application purpose of the host. When those protocols are used, OIP can communicate with a PLC concurrently.

Screens can be created easily using PLC standard parts.

## 2. MEMORY TABLES

The OIP has 2,048 memory tables, numbered 0 to 2,047, and each memory table is structured in two-byte words.

The memory tables have a system area, which is reserved for several specific purposes, and a data area, into which the received data from the host and the data to be sent to the host are to be written.

Memory tables

System area

Table number	Description
0	When data is written into this table, data within the range from table #1 to table #2 will be transmitted to the host.
1	Starting table number for host transmission (*1)
2	Ending table number for host transmission (*1)

\*1: If the values of table #1 and #2 are 15 or less, the value of table #0 will be transmitted to the host, or if the value of either table #1 or #2 is 16 or more, data within the specified range will be transmitted to the host.

Note: For Type I, do not write data into table #1 or #2 (since the data of table #1 and #2 is reset to zero during the start of the OIP automatically, only the data of memory #0 can be transmitted to the host).

## 3. DIFFERENCES BETWEEN TYPE I AND TYPE II

The OIP provides two types of memory link communication: Type I and Type II.

The differences between these two types are listed below.

See Section 4, "METHODS OF COMMUNICATION - ISSUING COMMANDS BETWEEN THE OIP AND THE HOST", for a detailed description of commands.

Differences between Type I and Type II

	Type I	Type II
Data that can be sent from the OIP to the host	Only one byte of data which has been written into table #0 can be sent in binary form to the host.	Data that has been written into table #0 value can be sent using a T-command. Data that has been written into table #1 and #2 range can be sent using a T- command.
Response to a normal write command	Response is not made to the host.	An S-command is sent to the host.
Response to an illegal command	Response is not made to the host.	An E-command is sent to the host.



## 4. METHODS OF COMMUNICATION (Issuing commands between the OIP and the host)

### 4.1 List of Commands

#### (1) Commands from the host

The following lists commands to be used to perform read/write operations on the memory tables:

Item		Command		Processing	Total data size that can be processed during one communication session	Direction of communication
		Symbol	ASCII code			
Batch reading	in word	R	52H	Data is continuously read on a table basis.	60 words	From host to OIP
Batch writing	in word	W	57H	Data is continuously written on a table basis.	125 words	From host to OIP
Random reading	in word	Y	59H	Data is read at random according to the specified table number	60 words	From host to OIP
Random writing	in word	K	4BH	Data is write at random according to the specified table number.	60 words	From host to OIP
	in bit	B	42H	Data writing is set/reset in bits according to the specified table number.	84 sets	From host to OIP

#### (2) Commands and responses from the OIP

The following lists responses to the read and write commands from the host, and data send commands entered using the OIP switches:

Item		Command		Processing	Total data size that can be processed during one communication session	Direction of communication
		Symbol	ASCII code			
Normal response	to a read command	A	41H	Data of the specified memory number is sent to the host.	Command-specified amount of data	From OIP to host
	to a write command	S	53H	Normal end of reception of the command is notified to the host.* <sup>1</sup>	-	From host to OIP
Error response		E	45H	It is notified to the host that the host command is not correct.* <sup>1</sup>	-	From OIP to host
Data send command		T	54H	The contents of the memory table are sent to the host by OIP switch entry etc.* <sup>1</sup>	60 words	From OIP to host

\*1: Only for Type II

## 4.2 Memory Table Batch Reading (in word)

How to carry out the control procedures for batch reading of the contents of the OIP memory tables from the host is described below using several examples of operations.

(1) Command control procedure for batch reading - Type I

(2) Command control procedure for batch reading - Type II

### **4.3 Memory Table Batch Writing (in word)**

How to carry out the control procedures for batch writing of data into the OIP memory tables from the host is described below using several examples of operations.

(1) Command control procedure for batch writing - Type I

(2) Command control procedure for batch writing - Type II



#### **4.4 Memory Table Random Reading (in word)**

How to carry out the control procedures for random reading of the contents of the OIP memory tables from the host is described below using several examples of operations.

(1) Command control procedure for random reading - Type I

(2) Command control procedure for random reading - Type II

#### **4.5 Memory Table Random Writing (in word)**

How to carry out the control procedures for random writing of data into the OIP memory tables from the host is described below using several examples of operations.

- (1) Command control procedure for random writing in word - Type I

(2) Command control procedure for random writing in word - Type II

#### **4.6 Memory Table Random Writing (in bit)**

How to carry out the control procedures for random writing of data in bits into the OIP memory tables from the host is described below using several examples of operations.

(1) Command control procedure for random writing in bits - Type I

(2) Command control procedure for random writing in bits - Type II

#### **4.7 Data Transmission from the OIP to the Host by Switch Entry etc.**

For the OIP, data writing into memory table #0 by switch entry etc. can be triggered to transmit the contents of the memory table to the host. How to carry out data transmission control procedures using this method is described below using several examples of operations.

Note: For data transmission from the OIP to the host, the types of executable transmission functions and data and the usable format of data significantly differ between Type I and Type II. See the description below for more specific differences.

##### **(1) Data transmission control procedure - Type I**

(2) Data transmission control procedure - Type II



## 5. ERROR RESPONSE – Only for Type II

During memory link communication of Type II, if the OIP receives an abnormal command from the host, the OIP will send error response, including an error code, to the host.

### 5.1 Format of the Error Response

### 5.2 Error Codes

The following lists error codes:

Error code	Error type	Description of the error
0001	Command error	A command other than “W”, “R”, “Y”, “K”, and “B”, has been received.
0002	Format error	ESC is missing at the beginning of the data.
		Characters other than “0” to “9” or “A” to “F”, have been received as the table number, continuous data size, or data.
		The length of the table number is not 4 characters.
		The length of the continuous data size is not 4 characters.
		The length of the data to be written is not 4 characters.
		The length of the Bit Position or Set/Reset of the bit-by-bit random write command is not 4 characters.
		A character other than “0” or “1”, has been set at Set/Reset of the bit-by-bit random write command.
		The continuous data size that has been specified by the batch read command is in excess of 60 words.
		The total amount of data to be written using the batch write command is in excess of 125 words.
		The total amount of data to be read using the random read command is in excess of 60 words.
		The total amount of data to be written using the word-by-word random write command is in excess of 125 words.
0010	Address error	The value of the table number is 2048 or higher.
		The value of [starting table number + continuous data size or starting table number + amount of data to be written] is 2048 or higher.
		The value of the table number specified by the write command is 2 or lower.

Note: If the total amount of data that can be processed using one communication command is exceeded, the error response of error code 0002 will be sent and then another error

response (error code not fixed) will follow.

## 6. SCREEN CREATION

To create screens, use the PLC-use standard parts that are attached to Screen Creator 5. In that case, set the operation parameters for the standard parts as follows:

Setting	
Sta. No.	Set 00.
Device name	Input MTBL (memory table number setting).

(Example) To display table #100 (decimal) using a numeric display unit (one of the standard parts for PLC use), set data as follows:

Operation parameter	
Sta. No.	00
Numeric disp unit connected device name	MTBL (100) or MTBL (&h64)

Denotes

hexadecimal.

## 7. RESTRICTIONS

Restrictions concerning memory link communication are listed below. For the total amount of data that can be processed using one communication command, refer to Section 4.1, "List of Commands" of Chapter V.

- (1) For Type I, when data is already written into table #0, the data to be sent to the host will not have an appended station number even if the station number in the communication format data is made valid. For further details, refer to Section 4.7, "Data Transmission from the OIP to the Host by Switch Entry etc". of Chapter V.
- (2) If memory link communication and a PLC are to be used together, the display rate decreases, compared with independent use of a PLC or of memory link communication. The display rate and data-processing rate of the OIP also decrease as the OIP-to-PLC or OIP-to-host traffic increases. When operating a PLC and the host at the same time using the OIP, be careful to ensure that communication efficiently occurs and that the traffic stays within its normal range.
- (3) For transmission of commands from the host, the lowercase alphabetic characters (a to z) cannot be used to specify a command or a table number. Uppercase characters A to F, R, W, Y, K must be used.

## 8. SETTING PROTOCOL TYPE

As with PLCs, before connecting the OIP to a host computer, the type of protocol must be set during creation of a screen using Screen Creator 5. If a screen for communicating with the host computer is created without the protocol type being set, an error will occur during creation of the data to be downloaded.

The setting procedure is described below. For further details, refer to Section 3, "Setting PLC Manufacture Name and Model Numbers" of Chapter II.

Select "Project Properties" on the "Project" menu.

Click on the "Connection Equipment" tag in the Properties window of the project.

Click on the " " mark of "Host Computer". A list is displayed. Select "Host Command Communication".

## 9. SETTING COMMUNICATION PARAMETERS

Call up the system mode screen of the OIP, and set the parameters for the desired communication port(s).

Communication type

Select a host computer.

Other parameters

Set other parameters according to the particular communication parameters of the selected host computer.

Defaults are as follows:

Baud rate = 9600, Parity = Even, Stop bits = 2, Data length = 8, Retry count = 1, Timeout time = 3 (sec), Xon/Xoff = None, Sum check = Yes

## 10. SETTING A STATION NUMBER

Use the following procedure to set a station number:

Select [System Setup] from the menu of the system mode.

When the system-setting menu is displayed, select [Setting of Communication Format with Host].

This displays the following screen:

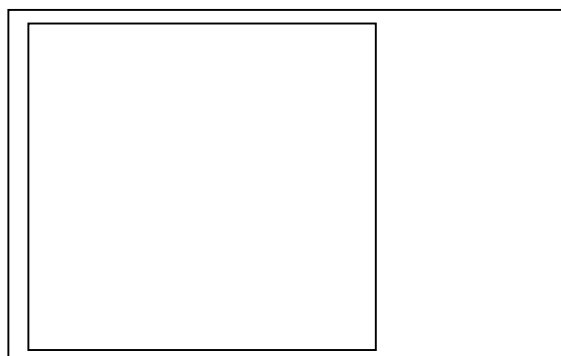

Touch the display frame of [Machine ID Number] to change the setting from [Not Use] over to [Use].

After the setting has been changed, touch [OK].

Set a station number in the required communication parameter. (For further information, refer to Section 3, "BEFORE TRIAL OPERATION" of Chapter I.)

Note: For memory link communication, the settings of all communication parameters, except for machine ID number (the station number), are ignored.

## 11. CABLE CONNECTION

RS-232C

RS-422/RS-485



Although an RS-232C/RS-422/RS-485 converter can be used to execute 1:N connection, always start this only from the master (host). Data will collide if 1:N connection is started from the slave (OIP) at the same time.

---

# **CHAPTER VI**

## **CONNECTION TO PERIPHERAL UNIT**

## 1. SETTING A MODEL

---



To connect the OIP to a peripheral unit, the model of the peripheral unit must be set during creation of a screen on Screen Creator 5. If a screen for operating the peripheral unit is created without a model being set, an error will occur during creation of the data to be downloaded.

The setting procedure is described below. For further details, refer to Section 3, "Setting PLC Manufacturer Name and Model Numbers" of Chapter II.

Open the sub-window for setting the unit to be connected.

Click [Set] that corresponds to the peripheral unit to be used, and then select its model.

Set the parameters of the port used for communication on the system mode screen of the OIP. For details of setting, see 3 "Before Trial Operation" in Section 1.

## 2. SETTING COMMUNICATION PARAMETERS

---

Set the parameters for the port that you are going to use.

Connected Device

Select the unit to be connected.

Other Parameters

Set other parameters according to the particular communication specifications of the unit.

The defaults of parameters are listed below.

Manufacturer	Baud Rate	Parity	Stop Bits	Data Length	Retry Count	Time Out (sec)	Xon/off	Check-Sum
Printer	9600	EVEN	2	8	0	20	ON	No
BCR	9600	NONE	2	8	0	0	OFF	Yes
Ten-key pad	9600	NONE	1	8	0	0	OFF	No

## 3. PRINTER

### 3.1 Function

Connection of a printer to the OIP allows you to perform these operations:

- Hardcopying the display
- Printing out character strings

During screen creation, the OIP provides you with special parts for the printer, such as a display-printing switch.

For further detailed information, refer to Standard Parts Catalog of Screen Creator 5 Operation Manual.

### 3.2 Connectible Models

#### 1) OA printer

Printers that use the ESC/P protocol or PR201 protocol can be connected to this system.



- ESC/P applies to the protocols compliant with the J83 group.
- This product does not support printers exclusively designed for Windows operating system supplied by Microsoft.

Note 1: PR201 is the standard protocol of NEC.

Note 2: ESC/P is the standard protocol of EPSON.

Note 3: Windows is the trademark of MICROSOFT.

#### 2) Industrial compact printer (monochrome)

The following printers have been already verified for operations.

Machine Type	Maker Name	I/F	Protocol	Print Item
MP-310	Nada Denshi	Centronics	No-protocol	Characters
TP-64UPG	Nada Denshi	Centronics	PR201	Characters and graphics*
DPU-20	Seiko Denshi	Centronics	No-protocol	Characters
μTP-80F (K)	Sanei Denki	Centronics	ESC/P	Characters
μTP-583	Sanei Denki	RS-232C	ESC/P	Characters

Note: In the no-protocol mode, K-Basic is used to describe control codes.

\* The GC56LC cannot use graphic printing.

#### 3) Color printer

Machine Type	Maker Name	I/F	Protocol	Print Item
MJ-700V2C or equivalent	EPSON	Centronics RS-232C	ESC/P	Characters and graphics

Note: If an RS-232C port is used to connect a printer, a serial I/F card (EPSON's option) is needed.



### 3.3 Printing a Screen

The following 4 modes can be used for printing screen data. Select the object mode on the "System Setup" screen of OIP.

Color specification mode

In this mode, 2 monochrome gradations can be used to print out data.

Fixed 8-color mode (color type OIP only)

In this mode, fixed 8 colors can be used to print out data.

Color DIZA mode (color type OIP only)

In this mode, intermediate colors can be used to print out data. The printing time is longer than that of other modes.

Printed colors differ a little from those displayed on screen.

Monochrome DIZA mode (color type OIP only)

In this mode, color-displayed data is printed out in the monochrome contrast.

### 3.4 Setting Printer Parameters and Notes for Use



- When a printer is to be used, set "ON" for the "printer" parameter on the "Project Property" of Screen Creator 5.  
(This setting is possible regardless of the printer type and protocol.)
- When the Centronics interface is used, the OIP only monitors the BUSY signal of the Centronics interface control signals. Thus, note that the OIP does not detect paper-out, etc. The OIP causes a time-out error when the printer stays busy for the "time-out period" set in System Setup. (For the "time-out period", see the following section.)
- When a printer is connected to the RS-232C port of this system, a serial I/F is needed for the printer.
- When a serial printer is to be used, set "ON" for the "X-ON/OFF control" parameter.  
If not, some data may be ignored. The OIP causes a time-out error if it does not receive XON within the "time-out period" set in System Setup. (For the "time-out period", see the following section.)  
Set "CS/RS control" for a printer that disables XON/XOFF control. In this case, only CH1 can be used.
- If a laser printer is used to print out screen data, printed items may become thin.

### 3.5 System Setting

If a printer is to be used, set "Output Port", "protocol", "Printer Mode", and "Time-Out" as follows in advance on the "System Setup" screen of OIP.

Select "System Setup" from the system mode menu.

Select "Printer Setup" from the system setting menu.

Select the output port.

Select the "protocol" according to the object printer.

Select "Printer Mode". Select "Monochrome" for a monochrome OIP.

Set the "Time-out".

This parameter disconnects the printer if no response is returned from the printer while the Parallel mode is set or an RS-232C port is used to control XON/XOFF.

### 3.6 Cable Connection

RS-232C (For serial printer)



The above connection example is for a general printer. The connection may differ among printers. Refer to the instruction manual of the printer before connecting it.

Centronics

The printer cable should be a PC-8894 (NEC) or equivalent. The pins of this OIP connector are assigned as shown below.

Pin No.	Signal Name	Pin No.	Signal Name
1	STB	8	D6
2	D0	9	D7
3	D1	10	–
4	D2	11	BUSY
5	D3	12	–
6	D4	13	–
7	D5	14	GND

## 4. BAR-CODE READER

### 4.1 Function

Connection of a bar-code reader (???) to the OIP allows previously read data to be displayed on the numeric display units of the OIP.

### 4.2 ???

Select “???” (bar-code reader) from the connection devices of the “Project Property” on Screen Creator 5.

#### 1) Environmental specifications

Item	Specifications
Operating temperature range	0 to 40°C
Operating humidity range	10 to 90% RH (no condensation/freezing) [Wet bulb temp. below 30°C]
Operating ambient illuminance	3000 luxes or less (daylight color fluorescent lamp)
Storage temperature range	–10 to –60°C (abrupt changes in temp., no condensation, and no freezing) [Wet bulb temp. below 30°C]
Storage humidity range	5 to 95%RH (abrupt changes in temp., no condensation, and no freezing) [Wet bulb temp. below 30°C]

#### 2) Reading specifications

Bar-code system (Note 1)	EAN-13, EAN-8 UPC-A, UPC-E 2 of 5 Interleaved, 2 of 5 Standard NW-7 (CODABAR), CODE39
Reflection value of bar code (Note 2)	White bar      0.45 or more
	Black bar      0.25 or less
PCS value (Note 2)	$\frac{(\text{Reflection value of white bar}) - (\text{Reflection value of black bar})}{\text{Reflection value of white bar}}$ 0.45
Bar code length	97 mm (max.), including left/right margins
Bar code height	10 mm (min.) [Recommended value] (Note 3)

Note 1: CODE39 Full ASCII is not supported.

Note 2: The required PCS value and reflection value must be obtained using a light source having a spectral length of 633 nm and a spectral range from 610 to 650 nm.

Note 3: An insufficient bar code height may deteriorate operational convenience and cause a delay in reading.

3) Setting bar-code reader parameters

All parameters of the bar-code reader are preset to their respective defaults prior to shipping. Use the parameters as they are. If the parameters become damaged, re-set them as follows:

- Form of interface           Set [Async] (asynchronous).
- Other parameters           Set all to defaults.

4) The operation of the bar-code reader

When the bar-code reader is connected to an RS-232C port of the OIP, power will turn on and at the same time, red light will be emitted from the reading window of the bar-code reader. The light will be emitted continuously or discontinuously.

A code can be read by setting the bar-code reader directly to it under that state.

When code reading succeeds and the code is transferred to the OIP, the reading sound will occur and at the same time, a green reading indicator LED will light.

### 4.3 Token's TCD8200/TCD8500

Select bar code readers bar code readers STX to EX (made by token, etc.) from the connection devices of the "Project Property" on the Screen Creator 5.

1) Reading specifications

Bar-code system

- All bar-codes that can be read with TCD8200/TCD8500

Operation mode

- N mode (Fix the DIP SW (SW1-10) at 0.)

Synchronous mode

- Synchronous mode 1, Synchronous mode 2, Synchronous mode 3, and Synchronous mode 4

Terminator

- STX to ETX (Fix the DIP SW (SW2-6) at 0.)

2) Notes on use



- **If the synchronous mode is other than mode 4, the synchronous input ON/OFF must be controlled with a parallel output, etc. from PLC or OIP.**
- **Bar-code data received from other devices is fetched in OIP as is, except for the terminator code.**

3) Connection

TCD8500 (RS-232C)

TCD8200 (RS-232C)

## 5. TEN-KEY BOARD

---

### 5.1 Function

An optional ten-key board (???) can be connected to perform external switch input operations.

### 5.2 Specifications

#### 1) Environmental specifications

Item	Specifications
Type	Panel-mounted
Stroke	0.3 mm
Pressure	150 g
Life	10,000,000 times
Keys	28 types: Numeric keys ([0] to [9]), [.] , [-], [BS], [CR], cursor keys ([ ], [ ], [ ], [ ]), [f-1] to [f-10]
Operating temperature range	0 to 50°C
Operating humidity range	35 to 85% RH

#### 2) Key codes

When a switch is pressed, the corresponding 8-bit JIS code is sent out.

Symbol	Code (HEX)	Symbol	Code (HEX)	Symbol	Code (HEX)
0	30	f1	80		1C
1	31	f2	81		1D
2	32	f3	82		1E
3	33	f4	83		1F
4	34	f5	84	.	2E
5	35	f6	85	-	2D
6	36	f7	86	BS	08
7	37	f8	87	RET	0D
8	38	f9	88		
9	39	f10	89		

### 5.3 Dimensional Outline Diagrams

(Unit: mm)