

Koyo®

Incremental Encoder Series TRD-2G

Operation Manual

Thank you for purchasing this series TRD-2G Incremental Encoders. Please read this Operation Manual carefully before applying this product.

PLEASE KEEP THIS MANUAL IN A SAFE PLACE!

KOYO ELECTRONICS (WUXI) CO.,LTD.

Add: 21st Floor, Building 1, No.599, Jianzhuxi Road, Binhu District, Wuxi, Jiangsu, P.R.China
Pc: 214072 Tel: (0510)85167888 Fax: (0510)85161393 KEW-M8171C-E

Safety Consideration

Warning This indicates contents which can cause large accidents leading to loss of life or severe injury when the indication is disregarded and wrong handling is executed.

Caution This indicates contents which can cause injury or material damage when the indication is disregarded and wrong handling is executed.

Explanation of the pictograms

- This symbol indicates a general prohibition.
- This symbol indicates a compulsory item or an instruction.

[Operating environment and conditions]

Warning

- Do not use in a combustible or explosive atmosphere. Otherwise personal injury or fire may be caused.
- Do not use this product for applications related to human safety. Use is assumed in an application where an accident or incorrect use will not immediately cause danger to humans.

[Operating environment and conditions]

Caution

- Use and store the equipment within the scope of the environment (vibrations, impact, temperature, humidity, etc.) specified in the specifications. Otherwise fire or product damage may be caused.
- Understand the product first before use it.

[Installation and wiring]

Warning

- Use only with the power supply voltage listed in the specifications. Otherwise fire, electric shock, or accidents may be caused.
- Use only with the wiring and layout specified in the specifications. Otherwise fire, electric shock, or accidents may be caused.
- Do not apply any kind of stress to the wires. Otherwise electric shock or fire may be caused.

Output circuit

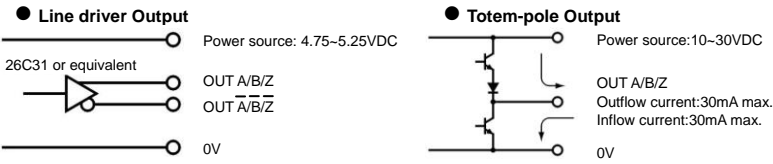

Connection

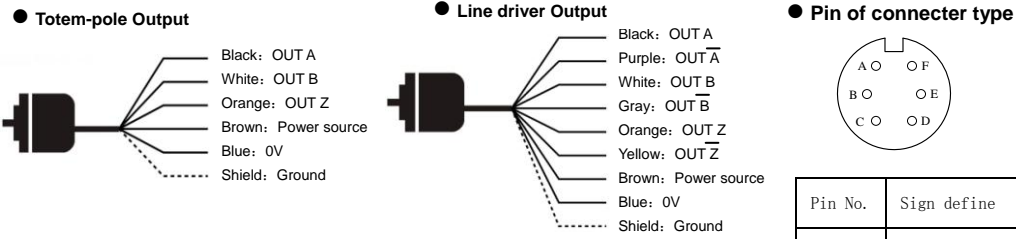

Output signal timing chart

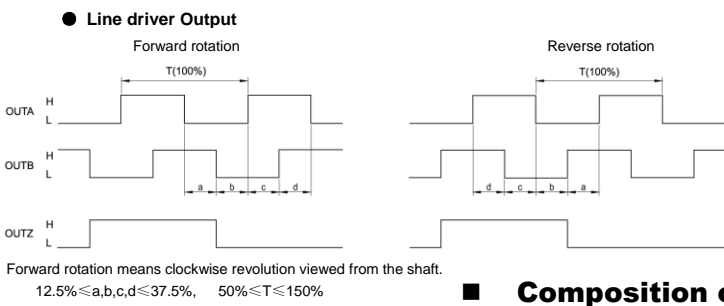

Composition of model number

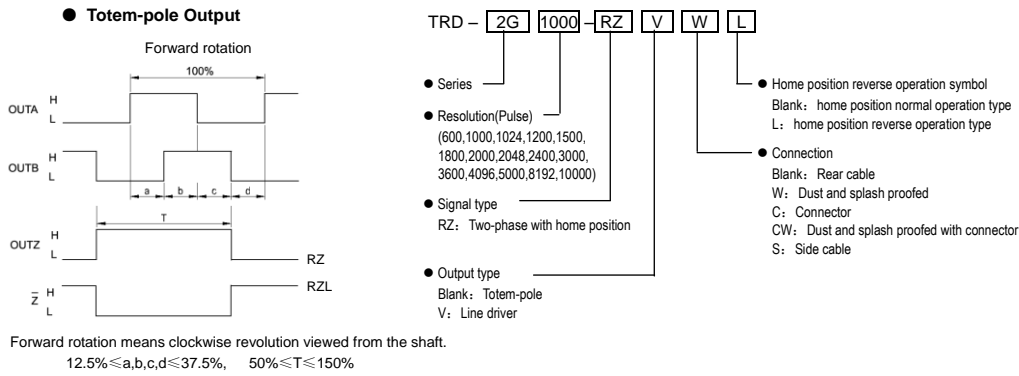

External dimensions (Cable length: 2m)

1. Dust proofed with side cable (S type)

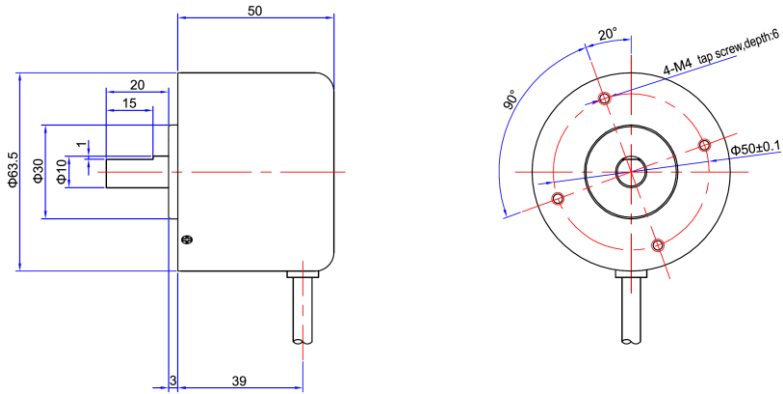

2. Dust and splash proofed with rear cable (W type)

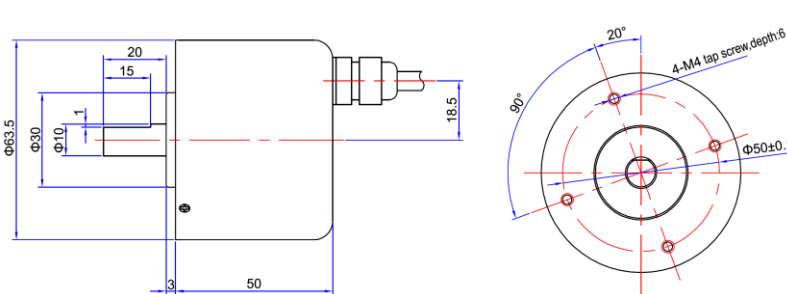

3. Connector with rear cable (C type)

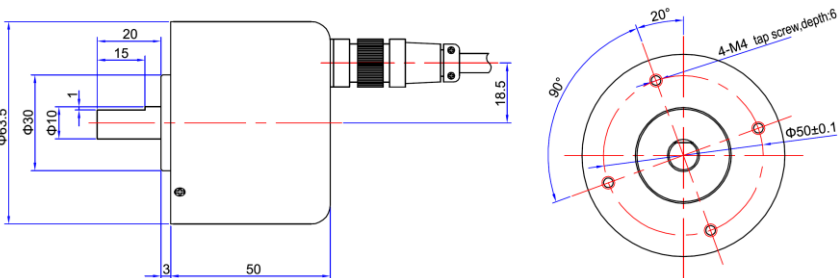

4. Connector /Dust and splash proofed with rear cable (CW type)

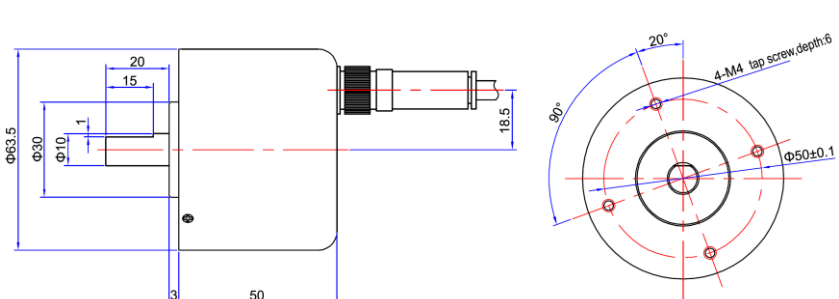

Mechanical specifications

Starting torque (+20°C)	≤ 0.003N · m	
Dust and splash proofed:	≤ 0.02N · m	
Shaft moment of inertia	5.7 × 10 ⁻⁶ kg · m ²	
Allowable shaft load	Radial	80N
	Axial	40N
Max. allowable rotation speed	5000rpm	
Service life of bearing	1.2 × 10 ⁹ revolutions (calculated value at the maximum load)	
Cable	Material	Oil-proofed PVC (with shielded cable)
	Nominal section area of core	0.3 mm ²
	External diameter	Approx. 6.0 mm
Weight	Approx. 350g (without cable)	

Environmental requirements

Ambient temperature	Operation temperature: -10 ~ +70°C Storage temperature: -25 ~ +85°C
Ambient humidity	35 ~ 85%RH (without condensation)
Withstand voltage	AC500V 1minute *Note 1
Insulation resistance	50MΩ min. (Excluding shield between power supply, signal cable, and case.)
Vibration resistance	Durable for 1h along 3 axes at 10 to 55Hz with 0.75 mm amplitude
Shock resistance	11ms with 490m/s ² applied 3 times 3 axes, total 18 times
Protection construction	Dust proofed: IP50 Dust and splash proofed: IP65

Note1: Shield cable is connected to the encoder body. The enclosure is connected with 0V through a 630V 0.01μF capacitance.

Electrical specifications

Type No.	TRD-2G		
Power source	Power source voltage	4.75~5.25VDC (Line driver output) 10~30VDC (Totem-pole output)	
	Allowable ripple	≤ 3%rms	
	Current consumption	100mA Max. (without load)	
Signal format	Two-phase A and B + Phase Z		
Max. response frequency	200kHz (Maximum response frequency/Pulse) × 60 (The encoder can not respond to revolution faster than the electric maximum allowable speed.)		
Electric Max. allowable speed	50% ± 25%		
Duty ratio	25% ± 12.5%		
Phase Shift	100% ± 50%		
Index signal width	2μs Max. (Cable: 2m, output current: 20mA (resistance load))		
Output	Rise and Fall time	2μs Max. (Cable: 2m, output current: 20mA (resistance load))	
	Output type	Line driver output (26C31 or equivalent)	Totem-pole output
		Output voltage	H-level voltage ≥ 2.5V L-level voltage ≤ 0.5VDC
	Output current	30mA max.	

Cautions for use

- Do not wire the cable in parallel with other power lines and do not share a duct with other cables.
- Use capacitors or surge absorption elements to remove the sparks caused by relays and switches in the control panel as far as possible.
- Be sure to connect all wires properly, as wrong wiring can damage the internal circuitry.
- Erroneous pulses may be caused at the time of power ON and power OFF. After power ON, wait for at least 0.5 sec before use.
- Use a specified coupling for connecting the encoder shaft and the shaft of a machine to be controlled. Do not squeeze the shaft into the coupling.
- The service life of the bearing is largely affected by the amount of load to the shaft. Try to reduce the load as much as possible.
- Do not disassemble the product. Do not expose the product for a long time to water, even if it is a dust-resistant, jet-proof type. Wipe off any water getting onto the product.
- As the rotary encoder is composed of precision parts, its function will be impaired when it is subjected to shocks. Use sufficient care for handling and mounting.

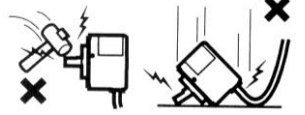

Options

